

**Tama Drums**  
**The**  
**strongest**  
**name**  
**for the**

**80's**





# TAMA

## The Strongest Name in Drums For the '80's

The decade of the '70's brought about some of the greatest basic changes in our approach to drum sets since someone first decided to put a bass drum on the floor. At Tama, we like to feel that we have shared in a large part of this growth.

During the last decade, popular music truly became the music of the people - with groups writing, producing and performing their own material. In the exploration of new areas of music, the need for new and improved instruments became evident.

Drums had remained pretty much the same for years and years, but fresh approaches to the drumming art demanded an update. Drummers began by improvising new and different equipment to suit their needs.

At Tama, we observed this improvisation and heeded the call, if you will.

The first product to put Tama on the percussion map was the introduction of the first production boom cymbal stand in 1974. Along with the boom came a whole new system of drum hardware that put real meaning into the words "Heavy Duty". From there, drummers discovered the excellent sound of Tama shells and their superiority in the recording studio. While we're tempted to say "The rest is history", we feel that the Tama chapter in the annals of percussion is just beginning. In this catalog you'll get an idea of what the next ten years has in store for drums. And in 1990 you can bet that wherever the art of drumming is, Tama will be there - maybe even a step ahead.







**BILLY COBHAM**  
One of the great drum explorers of all time.



**LENNY WHITE**  
Put fusion on the map with Return To Forever.

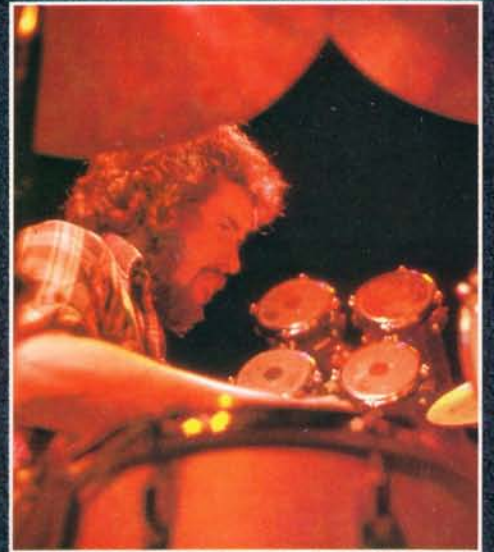

**JOE ENGLISH**  
From Sea Level to the flight of Wings.



**MICK FLEETWOOD**  
The driving force behind the most successful band of the '70's.

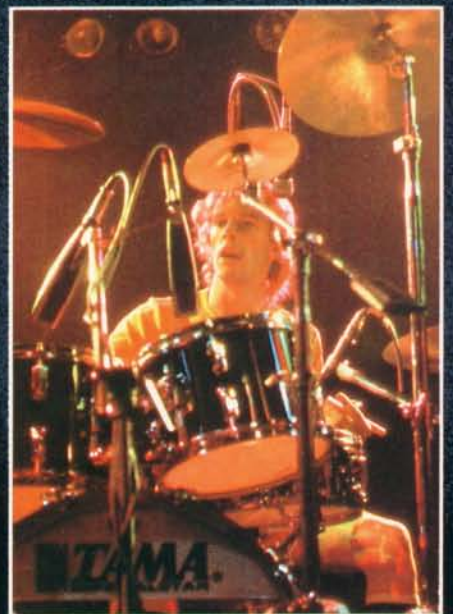

**STEWART COPELAND**  
The power of the New Wave unleashed with the Police.



**LIBERTY DEVITTO**  
Drummer man for the Piano Man - Billy Joel.

**JOHN PANOZZO**  
(STYX)





# Hardware

## IT JUST DON'T COME ANY STRONGER

When it comes to drum hardware, all the other manufacturers are fighting over second place. Beginning with the introduction of our now legendary boom stand in 1974, Tama has maintained superiority in the realm of hardware.

For 1980's, we thought it fitting that we give you a peek at the future of drum hardware. But you won't have to wait until 1990 to get it - Tama has it now. The list of Tama hardware innovations goes on and on, but here are a few of our latest features.



"It was Tama's hardware that first turned my head around - and I'm sure set the rest of the industry on its ear." - BILLY COBHAM

## TAMA HARDWARE

The strongest under the sun, moon or stage lights.

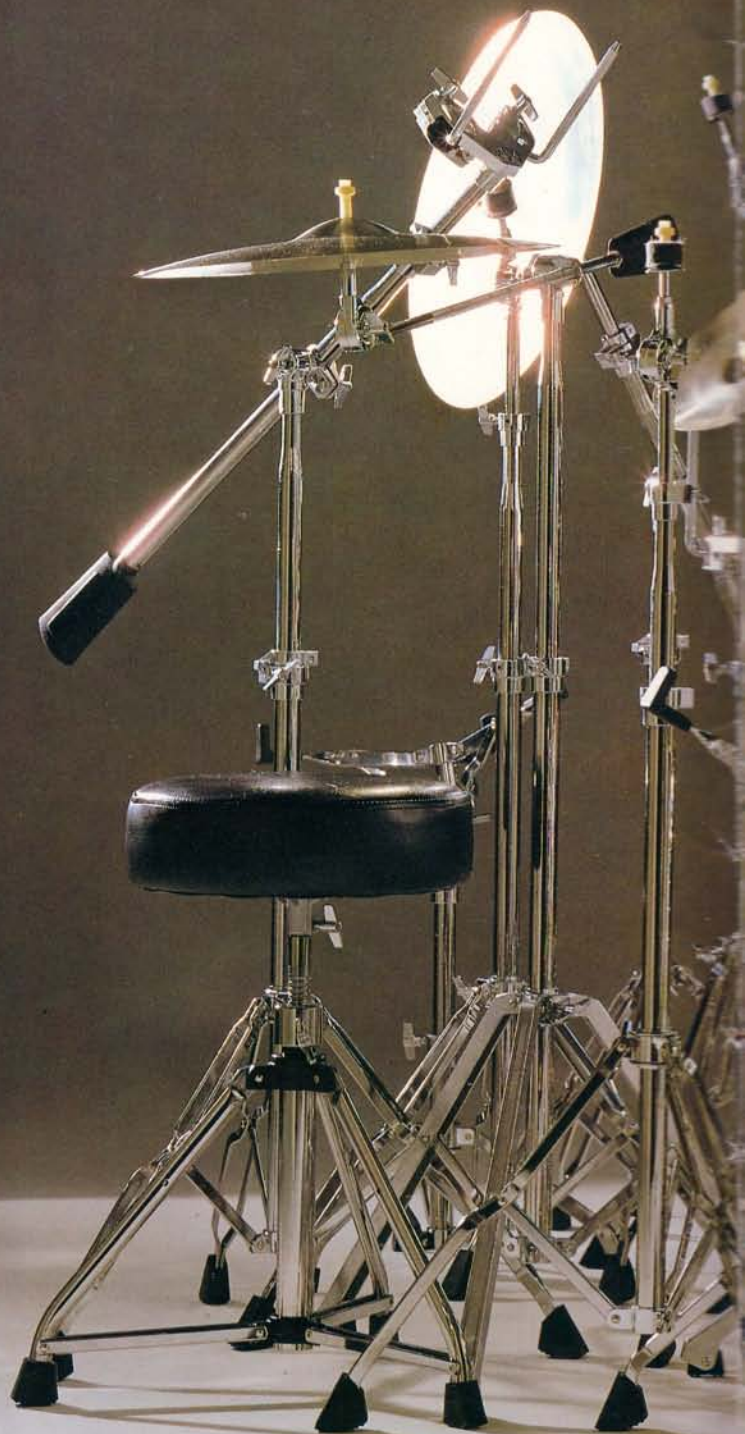



**WIDE-STANCE TRIPODS**

The strongest legs your hardware can stand on.

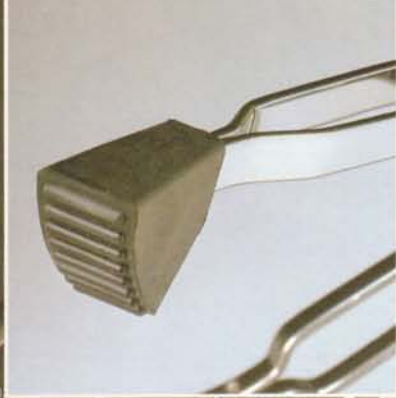

**NYLON BUSHING CLAMPS**

Perfect stability with fingertip pressure and can't mar the shafts.

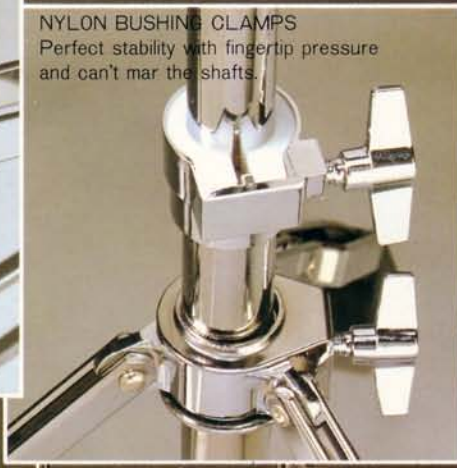

**OFFSET TILTER**

Folds completely out of the way to prevent damage in transport.



**TILTING CYMBAL STAND**

A Tama exclusive with extra versatility.

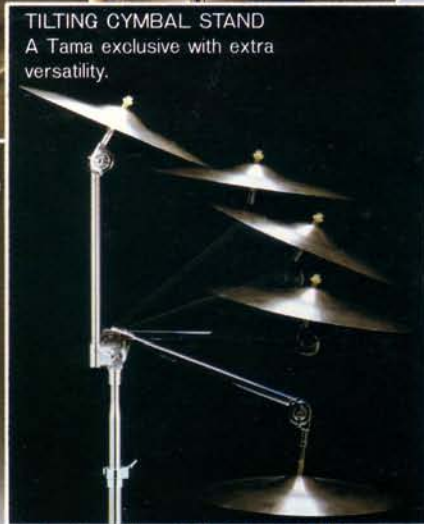

**TELESCOPING BOOM**

The world's most expensive boom stand - and worth every penny.

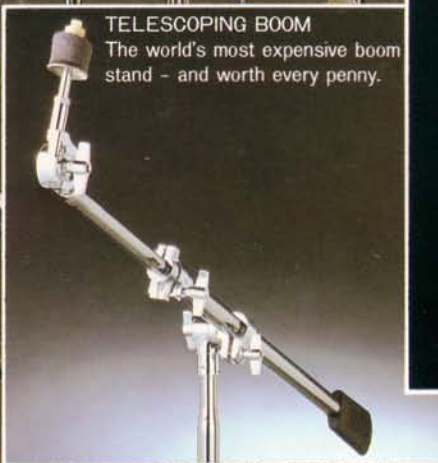

**TAMA SNARE STAND**

The exclusive brake drum tilter ends the search for the "just perfect" snare angle.

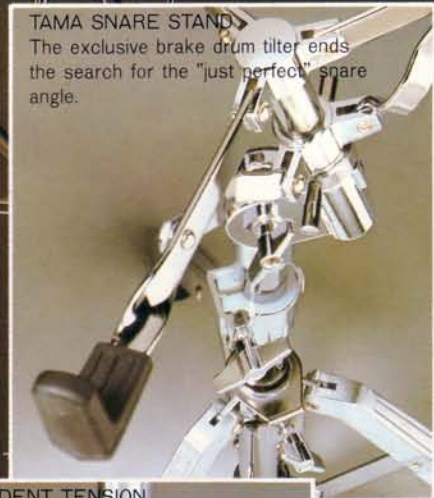

**KEY-LOCK MEMORY**

Adds stability and a memory to your boom stand and hi-hat settings.



**INDEPENDENT TENSION ADJUSTMENT**

Assures smooth operation and pinpoint tension.





# Titan Stands

The original Tama heavy duty stands that revolutionized the industry are still the standard by which others are measured. Titan hardware earned its laurels on the road with some of the world's hardest playing and hardest touring bands. Titan stands are also the most copied in the industry, but none of the imitators can claim the long list of Titan features.

Titan stands use double steel tripod legs with a wide, wide 36" span. The large diameter shafts are secured with the exclusive Tama Nylon Bushing Clamp that will not mar or distort the telescoping shafts.

But strength and stability are not the only reasons to consider Titan stands. Lightweight, flexible stands can actually absorb some of the energy when your cymbals, toms or snare vibrate. This energy is lost. By supporting your instruments firmly, Titan stands allow all the energy of your playing reach your listener's ears. So you owe it to your sound to use Titan stands.

## TITAN HARDWARE

- 6890 Snare Stand
- 6892 Straight Cymbal Stand
- 6893 Tilting Cymbal Stand
- 6894 Boom Arm Cymbal Stand
- 6904 Telescoping Boom Arm Cymbal Stand
- 6895 Hi-hat Stand
- 6790 Drum Throne



Titan Double Steel Legs



6790

6892



Titan Double Steel Legs



Molded-in-Place





6890

6893

6894

6904

6895



Rubber Tip



Spring adjustment Unit



Tama Key-Lock System



2-way Nylon Cymbal Nut 7082  
Offset Cymbal Tilter



Spiral Steel Shaft  
Non-loose Nut



# Spartan Stands



6795

6922

6920

6921

6926

6924

6925

Spartan hardware sets a new standard for strength with lightweight. The die-cast alloy tripod legs are strong, light and wide. The Two-Way Convertible Tip offers you the option of a rubber foot or steel stage spike. All Spartan stands also feature the Tama Nylon Bushing Clamp for smooth, positive height adjustment and long service.

Like all Tama snare stands, the Spartan 6920 features the Tama brake drum snare tilter. This important innovation doesn't use ratchet teeth or metal-to-metal contact. A revolutionary new friction material and conical drum design give you perfect stability at any angle with only fingertip pressure.

If the ultimate in technology and space age appearance are your thing - Tama Spartan is the hardware for you.

## SPARTAN HARDWARE

- 6920 Snare Stand
- 6921 Short Model Cymbal Stand
- 6922 Straight Cymbal Stand
- 6924 Boom Arm Cymbal Stand
- 6925 Hi-hat Stand
- 6926 Hi-hat Stand w/Holder
- 6795 Drum Throne



Two-Way Convertible Tip

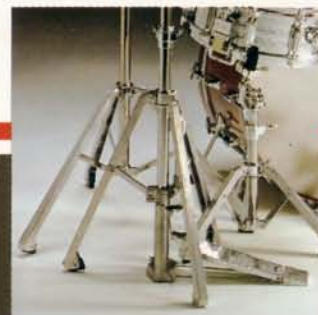

Spartan Die-cast Legs

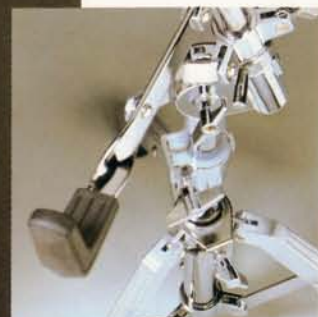

Molded-in-Place Rubber Tip



Non-slip Hi-hat Clutch



2-Way Nylon cymbal Nut



Spiral Steel Shaft



# Mercury Stands



6785

6872

6870

6874

6875

Tama Mercury stands feature single steel legs for those drummers who don't require super heavy duty strength. Despite their lighter weight, Mercury stands are as ample as any other on the market and still offer an extra wide stance for stability. Even at a moderate price, Mercury stands are loaded with exclusive Tama features like the nylon bushing clamp, offset cymbal tilter, contoured footboards, and the same brake drum snare tilter as Titan and Spartan.

The new Mercury Hi-hat and Throne also feature the new Tama Key-Lock that not only assures perfect height stability, but rotational stability as well.

## MERCURY HARDWARE

- 6870 Snare Stand
- 6872 Straight Cymbal Stand
- 6874 Boom Arm Cymbal Stand
- 6875 Hi-hat Stand
- 6785 Drum Throne



Mercury Wide Steel Legs



Mercury Wide Steel Legs



Brake Drum Snare Tilter



Tama Key-Lock System



Offset Cymbal Tilter



Tama Key-Lock System





## DOUBLE TOM TOM STANDS

The new line of Tama double tom tom stands is headed up with the telescoping Tom Tom Stand. This versatility addition to the line is specifically designed for use with smaller concert tom toms when they are placed above larger tom toms. With the exception of the 6799 stand, all new Tama double tom tom stands feature the new Tama Omni-Sphere tom tom holder. The Omni-Sphere gives you much expanded versatility of set-up and interchanges perfectly with any existing Tama tom toms.

- 6909      Telescoping Boom Double Tom Tom Stand
- 6899      Titan Double Tom Tom Stand
- 6899ST    Special Short Version of 6899 (not shown)
- 6869      Mercury Double Tom Tom Stand



## TAMA ROLLAWAY STANDS

With more drummers demanding a more versatile, stable and professional set up, Tama now introduces the ultimate in drum stands - the Tama Rollaway Stand. This stand features a heavy, high pressure die-cast base with lockable heavy casters. This versatile stand can hold four tom toms, or with optional Tama Multi-Clamps, can support up to eight tom toms or any combination of toms, cymbals and mikes.

The Rollaway Stand is fully adjustable, both in height and width, to accommodate any size drums or drum/cymbal combination. It comes complete with two Tama double tom tom holders, but can accept the upper portion of any Tama Spartan, Titan and Mercury Stand. Combined with the Tama Multi-Clamp System, it's the most versatile drum stand ever offered.

- 6901      Rollaway Stand, complete with two double tom tom holders.



## TOM TOM HOLDERS



### OMNI-SPHERE DOUBLE TOM TOM HOLDER

Our-never-ending search for the ultimate tom tom holder has led us to the Tama Omni-Sphere. This new double tom tom holder offers you virtually unlimited freedom of set-up. It's perfectly interchangeable with previous Tama tom tom holder and fits all standard Tama bass drum and tom tom brackets. The heart of the Omni-Sphere is a

hardened nylon ball joint that goes just where you want it. Adjusted lightly, it allows you to move the tom toms easily, but holds them in place. When you find the right position, just lock things up. Most other universal-type holders have parts that protrude into the tom tom shell. This is not only unsightly, but disturbs the natural resonance of the drum. All Tama mounting hardware is on the outside of the tom toms, allowing maximum freedom of tone.

## TAMA KEY-LOCK

A simple and effective way of giving your drumset a memory. A Key-Lock clamp fits on the mainshaft of the tom tom holder and locates into a keyway on the bass drum bracket, giving you a preset height and eliminating the possibility of rotation.

Mini Key-Locks are installed on the tom tom holder "L" rods and locate into keyways on the tom tom brackets. The Key-Lock system is simple and effective without cumbersome and expensive hardware.

## MULTI-TOM TOM HOLDER

By using the Tama Multi-Clamp system, your Tama double tom tom holder can be expanded into a triple or even quadruple tom tom holder.

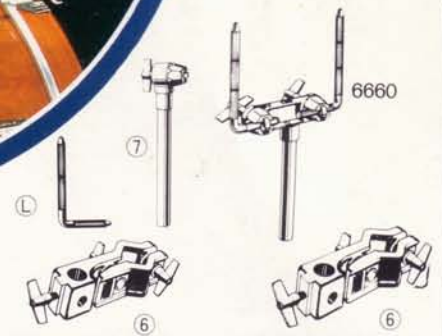

### 6681-C

Single Tom Tom Holder, complete with bracket.

### 6681-A

Single Tom Tom Holder, less bass drum mount casting and tom tom bracket.

### 6692-C

Double Tom Tom Holder complete with brackets.

### 6692-A

Double Tom Tom Holder, less bass drum mount casting and tom tom brackets.

### 67-L

Triple Tom Tom Adaptor, complete with Multi-Clamp, Ratchet Arm and "L" Rod.

### 6660-6

Extra-Twin Tom Tom Adaptor, complete with Tom Tom Holder and Multi-Clamp.



**Q : WHAT'S THE WORLD'S BEST  
BASS DRUM PEDAL ?**

**A : YOUR OWN.**

In interviews with hundreds of professional and amateur drummers around the country, we were surprised at the loyalty drummers show to their bass drum pedals. The fact is, that a once drummer becomes used to a particular pedal, that pedal becomes the best for him.

So, if you're going to get used to a drum pedal, why not make it the strongest, most adjustable and most consistent drum pedal on the market - the Tama King-Beat!

The King-Beat is one pedal that's designed to last a lifetime, and to give you consistent performance year in and year out. Just check these exclusive features.

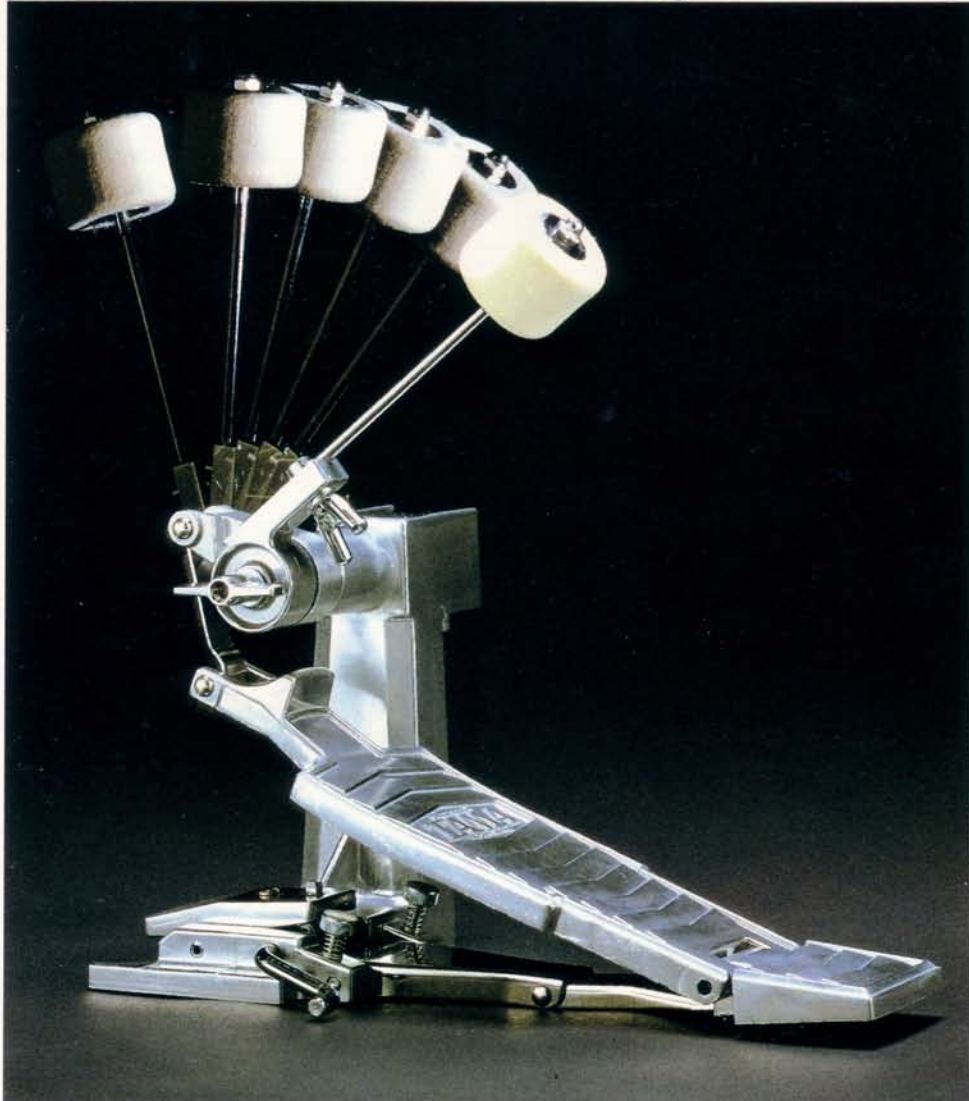
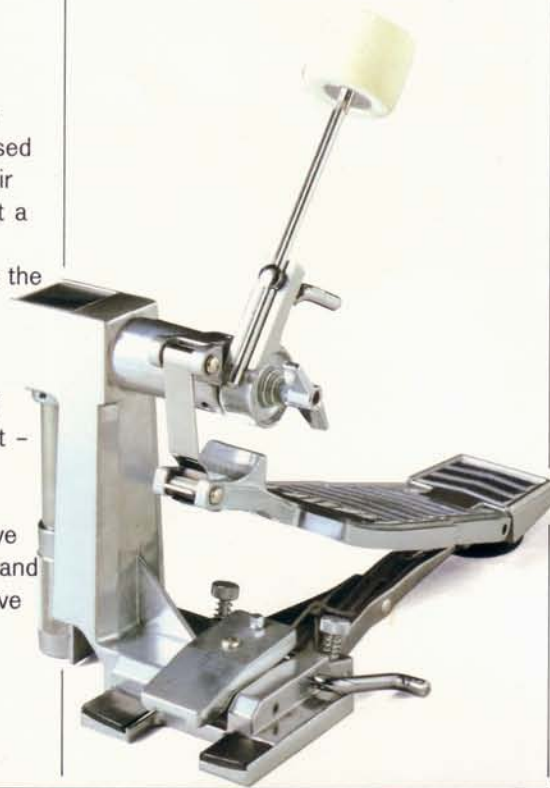

## BASS DRUM PEDAL

### 6755 KING-BEAT

- ① **Indestructible Compression Spring** - Tested to 3 million cycles without a failure.
- ② **Cam Actuated** - The spring is actuated by a special cam for a quick positive stroke and smooth return.



- ③ **New Design Footboard** - Heavy die-cast alloy and curved to fit the contour of your shoe.
- ④ **Heel Height Adjustment** - To adjust the angle of the footboard independent of all other adjustments.
- ⑤ **One-Touch Rim Clamp** - Less time to set up and break down.



- ⑥ **Quick Spring Adjustment** - External adjustment is easy and simple.
- ⑦ **Sealed Spring Housing** - The lubricant cannot get out and dirt cannot get in.
- ⑧ **Nylon Pushrod Bushing** - The spring pushrod glides in a nylon bushing for smooth and quiet action for a long, long time.
- ⑨ **Independent Stroke Angle Adjustment** - The stroke angle of the beater can be changed without changing the spring tension or the footboard angle.

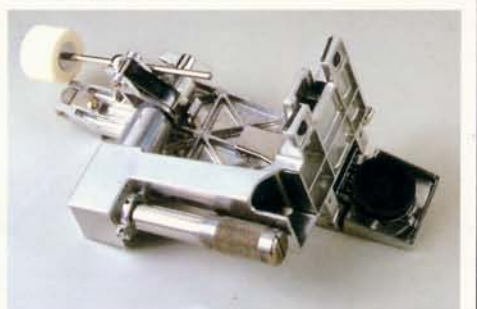



## BASS DRUM PEDAL

### 6740 HI-BEAT

The Hi-Beat pedal is a simple and straightforward pedal designed with long service and consistent action in mind. Here are just a few of its features.

- ① **Easy Spring Adjustment** - The knurled thumbscrew provides easy adjustment and the positive lock keeps it where you set it.
- ② **Adjustable Stroke Angle** - The beater stroke angle is adjustable independently of the spring tension.
- ③ **Built-In Anchors** - Help stop bass drum creep. Fully adjustable.
- ④ **Positive Beater Clamp** - Holds the beater without slipping or marring and weakening the beater shaft. Adjustable length for different bass drum sizes.
- ⑤ **Heavy Duty Cam Strap** - Specially processed and woven industrial nylon strap is many times stronger than leather. For smooth transfer of power from footboard to beater cam.

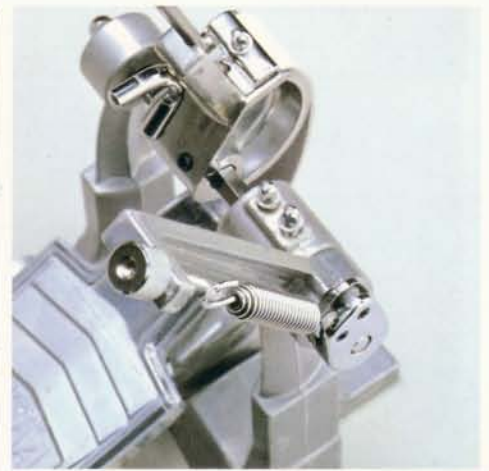

## BASS DRUM PEDAL

### 6730 FLEXI-FLYER

The Flexi-Flyer features:

- ① Flexible footboard-to-beater cam connection
- ② New design footboard
- ③ Easy spring adjustment
- ④ Improved cam strap
- ⑤ Lightweight parts for fast action
- ⑥ Precision die-cast parts

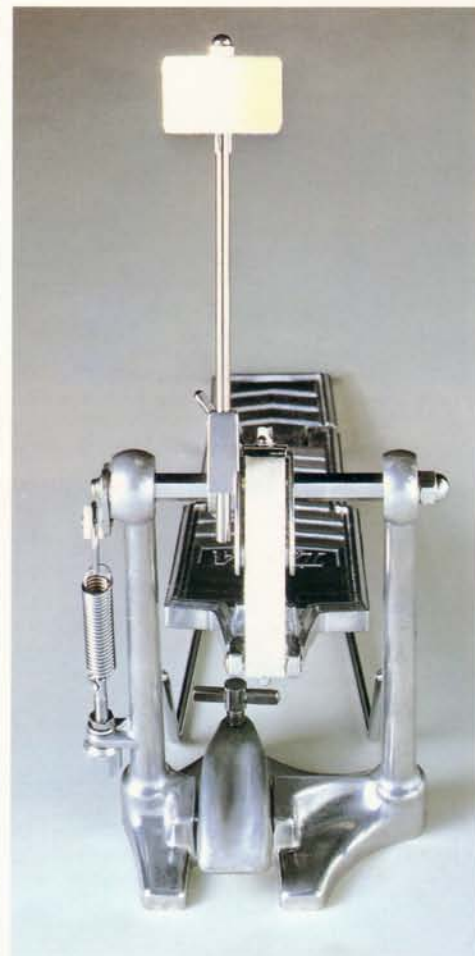



## THE TAMA MULTI-CLAMP HARDWARE SYSTEM

Today's drummer is using more and more accessories than his forerunners and more and more drummers are miking their drum sets for a more balanced group sound. The Tama Multi-Clamp Hardware System grew from the need to more adequately mount accessories and microphones.

You can now not only custom design your Tama set, but your Tama hardware as well. The Multi-Clamp System is based on the versatile multi-clamp with many, many optional parts for just about any application.

Extra tom toms can be added, extra cymbals placed anywhere around the kit, and complete set of mikes can be mounted to your existing hardware without purchasing new stands. The result is an efficient, good looking and professional set-up wherever you play.

- B 24" Mike Holder Rod
- C 12" Mike Holder Rod
- D "L" Shaped Mike Holder Rod
- I 24" Cymbal Holder Rod
- J 12" Cymbal Holder Rod
- K "L" Shaped Cymbal Holder Rod

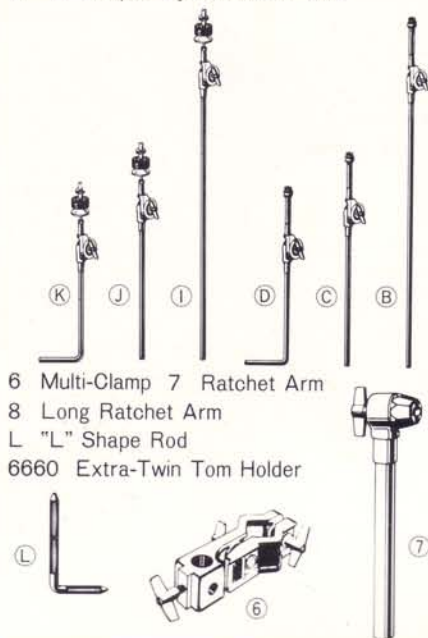

## CYMBAL HOLDERS

- 67-I w/24" straight rod
- 67-J w/12" straight rod
- 60-K w/"L" shaped rod

## MIKE HOLDER

- 67-B w/24" straight rod
- 67-C w/12" straight rod
- 60-D w/"L" shaped rod



6692 Double Tom Tom Holder  
+ 67-L (Cow-Bell Holder)



6692 Double Tom Tom Holder  
+ 67-J (Cymbal Holder)



6692 Double Tom Tom Holder  
+ 67-J (Cymbal Holder)



6692 Double Tom Tom Holder  
+ 67-L (Triple Tom Holder)



6692 Double Tom Tom Holder  
+ 6660-6 (Extra-Twin Tom Holder)



6692 Double Tom Tom Holder  
+ 67-J x2 (Cymbal Holders)



## SUGGESTIONS ON MIKING YOUR DRUM SET

The number and location of microphones will depend on your application and, of course, the number of drums. In a live situation, where you are miking drums through a sound reinforcement system, a five piece set can be adequately miked with 3 to 6 mikes. The bass drum, snare, and floor tom tom should have their own mikes and the mounted tom toms may share a mike placed near the top head and between both drums. You'll probably find that the leakage from these mikes will pick up the cymbals and the hi-hat quite adequately. In a larger concert situation, you may find it necessary to mike the hi-hat individually and use one or two overheads for cymbals.

When using concert tom toms, many soundmen prefer to use one mike per drum and place the mike up inside the shell. This technique is most effective, but if you have eight concert tom toms, you'll need eight mikes.

For recording, just about any percussive surface is miked individually

for the maximum control. Recording engineers often mike the snare from both the top and the bottom in order to be able to mix the snare very precisely. Much of the other mike placement is trial and error until you get a sound you like.

If your budget or mixer inputs limit you to two or three mikes for your entire set, a bass drum mike and an overhead pointing down at the snare drum will get you by with surprisingly good results. Anyway you mike drums, however, the Tama Multi-Clamp system can be do the job.

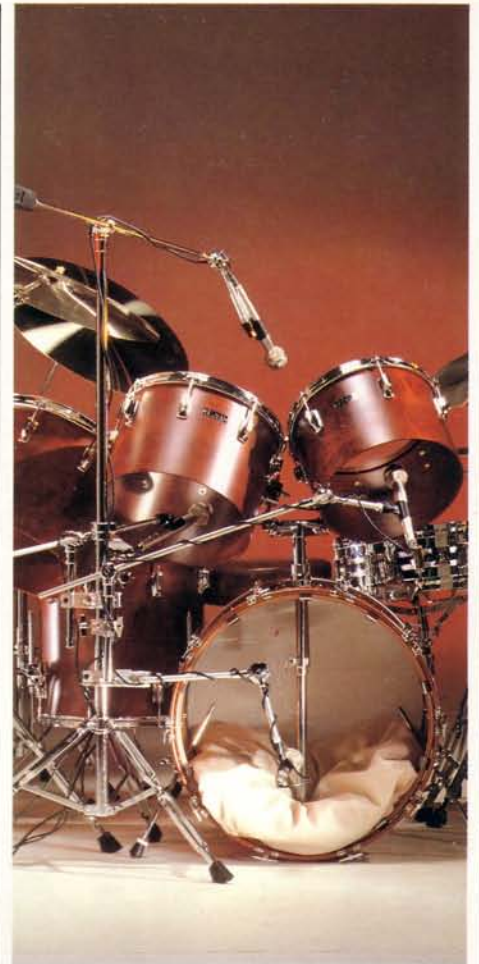
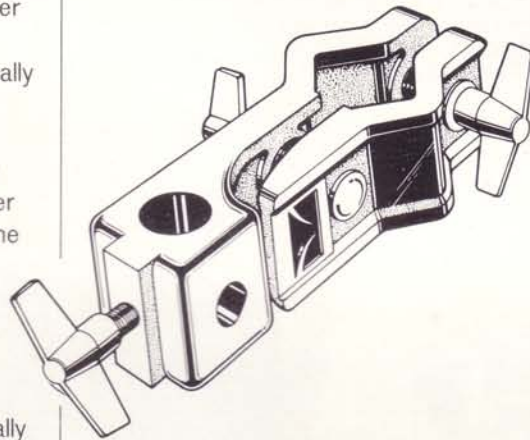

6692 Double Tom Tom Holder  
+ 67-C (Mike Holder)



6892 Cymbal Stand  
+ 67-J (Cymbal Holder)  
+ 67-C (Mike Holder)



6894 Boom Arm Cymbal Stand  
+ 67-J x2 (Cymbal Holders)



6909 Telescoping Boom Arm  
Double Tom Tom Stand  
+ 67-J (Cymbal Holder)



6890 Snare Stand  
+ 67-C (Mike Holder)



6892 Cymbal Stand  
+ 60-K (Cymbal Holder)





## THE SNARE DRUM THE HEART OF YOUR SET

Your snare drum is right at the heart of your sound. If your snare doesn't make it - even the best set can't carry you through. With this in mind, we've devoted more time to the research and development of snares than to any other part of the set.

If it's one thing we've discovered about snare drums, it's that nearly every drummer is looking for his own "signature" snare sound. So for this reason we offer no fewer than 38 different shell, strainer and snare bed combinations. Quite frankly, other drum makers think we're nuts offering so many choices, but if their two or three models don't please you perfectly, come on over to Tama.



## TAMA SHELLS FIVE WAYS TO SOUND GREAT

Shell material is one of the primary reasons why a drum sounds the way it does. Tama offers you a choice of five different shell materials. Each one in its own way sounds great.

**BELL BRASS** - Sand-cast and hand-turned for the purest snare sound ever achieved.

**ROSEWOOD** - 12-ply of choice rosewood for the "woodiest" tone.

**FIBREGLASS** - Centrifugal molded with amazing power to the tone.

**ARTWOOD** - Beautifully inlaid 6-ply maple for warmth and depth.

**METAL** - Seamless for perfect roundness.



## ONE-TOUCH TONE CONTROL

The Tama One-Touch tone control has brought raves from drummers everywhere. The exact amount of tone control you desire can be preset and then brought in and out on cue-precise and accurate every time.



## TAMA PC HOOPS THE ONLY WAY TO A PERFECT CIRCLE

Tama "PC" high pressure die-cast alloy hoops have many advantages over conventional hoops. All Tama snare drums feature the PC hoop to assure a perfect fit to both the drum head and shell. PC hoops won't flex the way conventional stamped hoops will, so tuning and head tension are more consistent and accurate all the way around the drum. And because Tama PC hoops are solid and warp-free, rim shots are bigger, crisper and cleaner than ever before.



## TAMA STRAINERS THREE KINDS OF VERSATILITY

No one strainer can satisfy the needs of all players, so Tama offers three. The Tama KG Parallel action strainer offers the finest adjustment over the widest range of any strainer available. It features separate control over snare tension and head pressure. Snare operation is exactly parallel to the head surface and there are no strings or tabs to stretch or break.

The Tama RB roller bed strainer features special guide rollers to govern the position of the snare bed against the head. The spring loaded rollers also push the snare bed positively away from the head when the strainer is released.

The Tama SS2 strainer puts the tension adjustment and throwoff on the same side of the drum. This simple and functional strainer fits the needs of most drummers.

## TAMA SNARE BEDS THREE WAYS TO EXCELLENT RESPONSE

The choice of shell material, and shell depth are not the only contributing factors to the sound of a drum. The choice of snare bed is also important. To complete your choice, pick one of these Tama snare beds.

**Tama Steel Bed** - The bed strands are heat treated spring steel for long life and consistent response. The choice of most drummers.

**Tama AC Snare Bed** - This new development uses steel aircraft control cable which will not stretch under any circumstances. It has a very short rebound distance from the head and a lightning quick response. Developed by Billy Cobham, it is highly recommended for players with a heavy hand.

**Tama Bell Brass Snare Bed** - In a situation where clarity of tone is desired, nothing surpasses the Bell Brass Snare Bed. The strands are made up of specially treated bell brass coils for a very warm and direct snare tone.

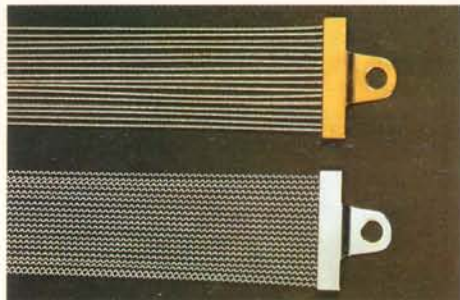

## TAMA SERIAL NUMBERS

Each individual Tama drum, including snare drums, features a serial number imprinted on the medallion. If you've ever tried to insure your set, you'll know what a help this can be.





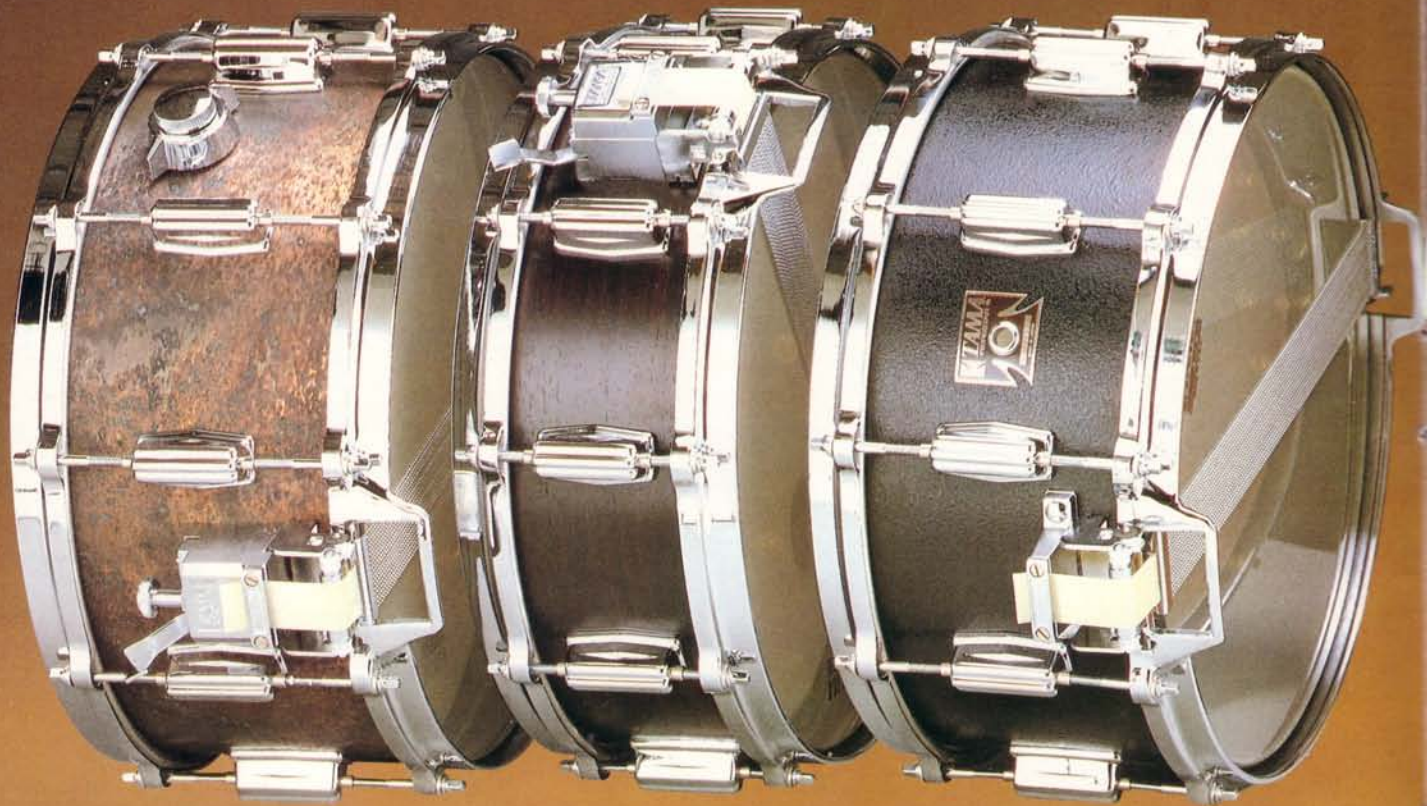

### TAMA MASTERCRAFT SNARE DRUMS

Tama Mastercraft Snare Drums are available in five different shell materials and two different shell depths. Each one will give you excellent and distinctive performance.

All Tama Mastercraft snare drums feature the Tama RB Roller Bed strainer for quick and positive action and simple, versatile adjustment. Both sides of the strainer feature a spring-loaded roller for smooth and positive performance.

- 6035 Steel Snare Bed
- 6037 Bell Brass Snare Bed (option)
- 6039 AC Snare Bed (option)



### MASTERCRAFT BELL BRASS



The Mastercraft Bell Brass snare drum is certainly the most amazing snare you've ever heard. The shell is sand cast in the manner of top quality cymbals and, of course, bells. This 12mm casting is hand-turned down to a 5mm thickness and burnished to a natural brass patina. The Tone of a Mastercraft Bell Brass snare will grow sweeter and warmer with each passing year, making this a drum that you'll treasure forever.

- BB-155 5" x 14"
- BB-156 6 1/2" x 14"

### MASTERCRAFT ROSEWOOD



The Mastercraft Rosewood snare drum is made of 12 plies of select rosewood, resulting in the most powerful wood snare ever made. Other manufacturers offering rosewood snare drums merely place a thin veneer of rosewood over their regular wood shell - Tama is the only one to offer you all-rosewood construction. Fitted with Tama PC die cast hoops and the Tama RB roller bed strainer, the Mastercraft Rosewood is one class drum.

- RW-255 5" x 14"
- RW-256 6 1/2" x 14"





### MASTERCRAFT FIBREGLASS



The Mastercraft Fibreglass features the Tama "Black Fibreglass" shell for amazing strength and power. This heavy shell provides a bright, loud tone that is also rich and full. The shell is finished in mat black textured epoxy for durability and appearance. With its precision machined sound edge, the Mastercraft Fibreglass snare is the cleanest and fattest fibreglass snare on the market.

FG-355 5" x 14"  
 FG-356 6 1/2" x 14"

### MASTERCRAFT ARTWOOD



The Mastercraft Artwood snare is made of 6 plies of rock maple for a warm, woody tone. The shell is inlaid with a beautiful multi-section marquetry of stained wood. This beauty is brought out with a high gloss lacquer finish that is the finest you'll see on any drum. As will all of the Mastercraft Series, the Artwood is furnished with steel snare bed as standard equipment.

AW-455 5" x 14"  
 AW-456 6 1/2" x 14"

### MASTERCRAFT STEEL



The Mastercraft Steel snare drum is made of seamless metal for the optimum in metal snare performance. The special process used to make this drum assures a perfectly round shell every time. Combined with PC die cast hoops the Mastercraft Metal offers you a level of precision that other drum makers can only envy. The sound edge is rolled to a precise 2mm radius, giving your heads maximum freedom of vibration.

8055 5" x 14"  
 8056 6 1/2" x 14"





## TAMA KING-BEAT SNARE DRUMS

The King-Beat features a deep-drawn seamless metal shell to assure perfect roundness. Combined with the Tama PC die cast hoops, your heads will fit perfectly and the drum will be easier to tune and keep in tune. The uniform thickness of the shell will give you a consistency and clarity in tone that you've not experienced with any other drum of non-seamless construction.

Tama seamless shells have a warm and fat sound that won't break up or choke even in the fastest and loudest rolls. The inner flanges of the shell are set at a perfect 45° angle for added strength and increased acoustic response, particularly when playing near the edge of the head.

The Tama King-Beat also features the Tama KG parallel action strainer. This state-of-the-art strainer offers you the finest adjustment over the widest range of any strainer available. It features separate control over snare tension and head pressure. Snare operation is

exactly parallel to the head and there are no strings or tabs to break or stretch.

## KING-BEAT SNARE DRUMS

- 8005 5" x 14"
- 8006 6 1/2" x 14"
- Tama Ambassador Heads
- Parallel Action Strainer
- PC Die-Cast Hoops
- One-Touch Tone Control
- KG Steel Snare Bed

## KING-BEAT SNAPPY SNARES

Tama King-Beat Snare Drum is furnished with steel snare bed as standard equipment.

- 6025 Steel Snare Bed
- 6045 AC Snare Bed (option)



## KING-BEAT STRAINER

The KG parallel Action Strainer - The most adjustable strainer in the industry.







### TAMA POWERLINE SNARE DRUMS

Tama Powerline Snare Drums are available in either seamless metal or 6-ply maple construction. They feature the Tama SS2 strainer for a simple, functional and versatile operation. The SS2 strainer places the throwoff and tension adjustment on the same side of the drum for convenience and simplicity. Powerline snare drums also feature the exclusive Tama One-Touch Tone Control. This internal muffler can be preset to any desired amount of tone control and brought in and out precisely when you want it. You won't ever again have to search for that "just perfect" sound.

### STRAINER

Powerline Snare Drums feature the SS2 strainer.



### SNAPPY SNARES

Tama Powerline Snare Drum is furnished with steel snare bed as standard equipment.

- 6020-13 Steel Snare Bed
- 6021 Bell Brass Snare Bed (option)

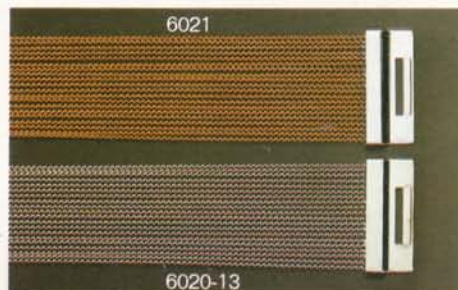

### POWERLINE SEAMLESS METAL SHELL SNARE DRUMS

- 8065 5" x 14"
- 8066 6 1/2" x 14"



### POWERLINE ARTWOOD SHELL SNARE DRUMS

- AW-555 5" x 14"
- AW-556 6 1/2" x 14"  
(Natural finish only)



- Tama Ambassador Heads
- SS-2 Snare Strainer
- Triple Flanged Hoops
- One-Touch Tone Control
- SS Steel Snare Bed



# TAMA

The Drummers' Choice For The '80's



JOE ENGLISH (SEA LEVEL)



RICHARD ADELMAN  
(DONNA SUMMER BAND)



BILLY COBHAM



TRIS IMBODEN (KENNY LOGGINS BAND)



STEWART COPELAND (THE POLICE)



TOMMY STINSON  
(GODIEGO)



LENNY WHITE



TERRY BOZZIO (U.K.)



DUFFY JACKSON  
(COUNT BASIE ORCHESTRA)



RICHARD DAUTIN



MICK FLEETWOOD (FLEETWOOD MAC)



JOHN WARE (EMMYLOU HARRIS)



JACKSON SPIRES (BLACKFOOT)



IAN HOFFMAN



STAN LYNCH  
(TOM PETTY & HEARTBREAKERS)



SIMON PHILLIPS  
(STANLEY CLARK GROUP)



JOHN PANOZZO (STYX)





**Simon Crowe (Boomtown Rats)**



**Liberty Devitto (Billy Joel)**



**Stomu Yamashta**



**Ken Caillat (The Doobie Brothers)**



**Gene Dunlap (Earl Klugh Band)**



**Mike Kozak (Teaze)**



**Georges Jouvin**



**Willie Leacox (America)**

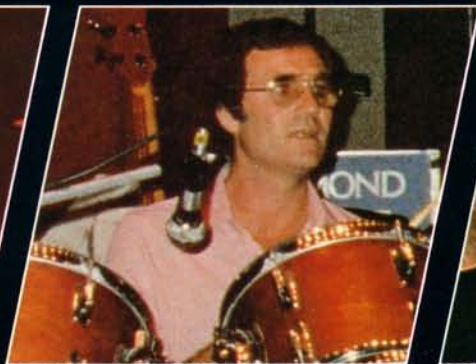

**Armond Cavallaro (Raymond Lefevre)**



**Dave Houghton (Joe Jackson Group)**



**Brian Downey (Thin Lizzy)**



**Ced Sharpley (Gary Numan Band)**



**Don Marrs (Charly McClain Group)**



**Preston Heyman (Kate Bush Band)**



**Neil Peart (Rush) photo by Fin Costello**



**Dennis W. Lee (The Cumberlandds)**





BILLY COBHAM

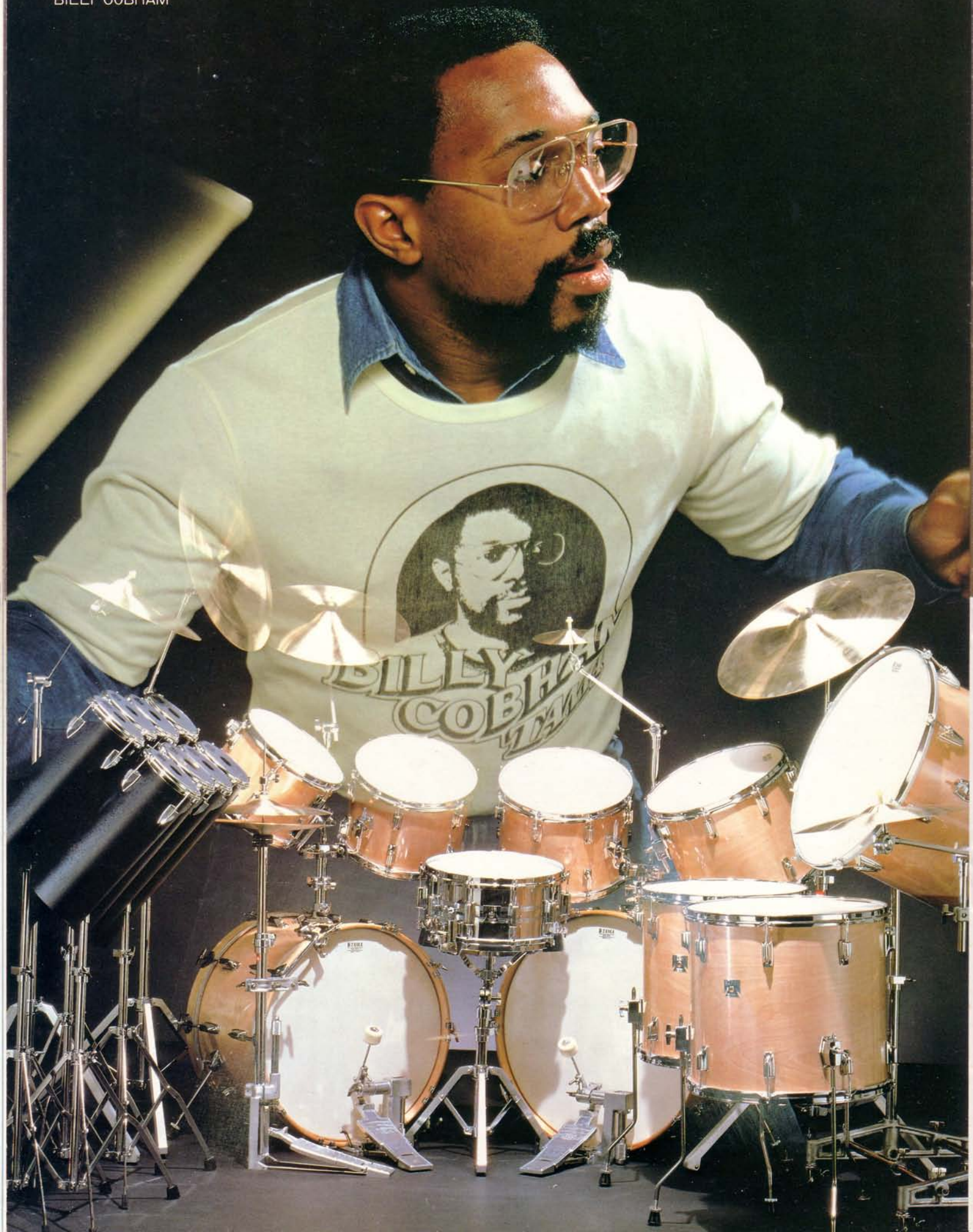



## TAMA SUPERSTAR DRUMS



**TAMA SUPERSTAR** - Today's wood drum. Made of 6 plies of specially selected and cured birch in a special "Heat Compression" mold, Tama Superstar drums have the strength and durability to hold up on the road. Because of this unique manufacturing process and an exclusive angle seaming technique, Superstar drums have a warm, woody tone with outstanding volume.

Listen to what Billy Cobham has to say about his Superstar drums. "I've long been searching for wood drums with enough power and volume for my application. Finally I've found them - Tama Superstar. There's something inherently beautiful and instinctively pleasing about the sound of wood drums. After all, they've been with us for thousands of years. But until now, I haven't been able to find that sound in a drum that can take it."

In addition to the "Heat Compression" process, the seams in Superstar drums are staggered around the perimeter of the drum shell to avoid any weak spots. You'll also notice that, unlike other drums, the seams are angled. This technique results in a better fit of all the plies and provides additional resistance to out-of-roundness. Combined with the strongest hardware in the industry, Tama Superstar drums give you the best of both worlds - unexcelled tone and unparalleled strength.

The natural beauty of Superstar drums is enhanced by three beautiful finishes. For those who prefer the natural look, a clear gloss lacquer finish. If the warmth of a Dark Stain finish is your desire, we've got that too. And now, Superstar drums are available in the stunning new Aqua marine finish.



We also think you'll find the finish on the inside of your Superstar shells as pleasing as the finish on the outside. This attention to detail assures you of the best acoustic response possible. Furthermore, Superstar drums have no hardware or mufflers which protrude into the resonant chamber. All tom brackets mount to the outside and if muffling is desired, **Tama Quick-Release external mufflers 6553** are available options.



So if the ultimate drum set is what you're after, Tama Superstar should be at the top of your list. We believe that you won't find a drum anywhere that can compare with the features and craftsmanship of Superstar. The Superstar sets illustrated here begin with modest outfits and progress to the more complex. These outfit suggestions are a result of the preferences you have shown for relative drum sizes. But you need not feel limited by what we shown here. You may order individual drums and hardware to create your own custom set.

**NOTE:** Wood is a natural material and being so, is subject to certain variations. While of all our wood is carefully selected and our sets carefully color matched, it is impossible to insure that stained drums will always be of exactly the same shade. We hope you feel as we do that these subtle variations add character and individuality to the instrument.

## SUPERSTAR INDIVIDUAL DRUMS

### BASS DRUMS includes spurs.

9818	14" x 18"	9822	14" x 22"
9820	14" x 20"	9824	14" x 24"



### FLOOR TOM TOMS includes legs.

9834	14" x 14"	9838	16" x 18"
9836	16" x 16"	9840	18" x 20"



### TOM TOMS

9808	8" x 8"	9813	9" x 13"
9810	8" x 10"	9814	10" x 14"
9812	8" x 12"	9815	12" x 15"



### CONCERT TOM TOMS

9856	5 1/2" x 6"	9860	6 1/2" x 10"
9858	5 1/2" x 8"	9862	8" x 12"
6899	Stand	6899	Stand

### Hi-Pitch outfit No. 9868

9863	9" x 13"	9865	12" x 15"
9864	10" x 14"	9866	14" x 16"
6899	Stand	6899	Stand

### Low-Pitch outfit No. 9869

### Complete 8-pcs. outfit No. 9870





50



50+1

### SUPERSTAR 50

OUTFIT No. 9700

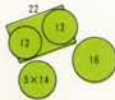

- 9822 14" x 22" Bass Drum
- 6692 Double Tom Tom Holder
- 8055 5" x 14" Snare Drum
- 9812 8" x 12" Tom Tom
- 9813 9" x 13" Tom Tom
- 9836 16" x 16" Floor Tom Tom

- 6755 King-Beat Drum Pedal
- 6890 Titan Snare Stand
- 6895 Titan Hi-hat Stand
- 6892 Titan Cymbal Stands (2)
- 5B Drum Sticks

Cymbals not included.  
Finish shown: Aqua Marine

### SUPERSTAR MEGA 50

OUTFIT No. 9710

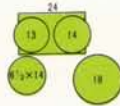

- 9824 14" x 24" Bass Drum
- 6692 Double Tom Tom Holder
- 8056 6 1/2" x 14" Snare Drum
- 9813 9" x 13" Tom Tom
- 9814 10" x 14" Tom Tom
- 9838 16" x 18" Floor Tom Tom

- 6755 King-Beat Drum Pedal
- 6890 Titan Snare Stand
- 6895 Titan Hi-hat Stand
- 6892 Titan Cymbal Stands (2)
- 5B Drum Sticks

Cymbals not included.  
Finish shown: Super Maple

### SUPERSTAR 50+1

OUTFIT No. 9701

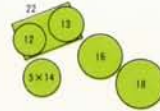

- 9838 16" x 18" Floor Tom Tom
- 6894 Titan Cymbal Stand

### SUPERSTAR MEGA 50+1

OUTFIT No. 9711

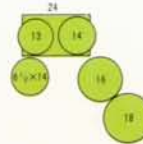

- 9836 16" x 16" Floor Tom Tom
- 6894 Titan Cymbal Stand

### SUPERSTAR 50+2

OUTFIT No. 9702

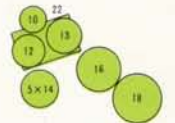

- 9810 8" x 10" Tom Tom
- 9838 16" x 18" Floor Tom Tom
- 6894 Titan Cymbal Stand
- 67-L Triple Tom Tom Adaptor
- 67-J Cymbal Holder

### SUPERSTAR MEGA 50+2

OUTFIT No. 9712

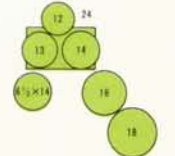

- 9812 8" x 12" Tom Tom
- 9836 16" x 16" Floor Tom Tom
- 6894 Titan Cymbal Stand
- 67-L Triple Tom Tom Adaptor
- 67-J Cymbal Holder



MEGA 50



MEGA 50+2





50+3

**SUPERSTAR 50+3**

OUTFIT No. 9703

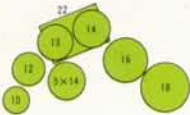

- 9810 8" x 10" Tom Tom
- 9814 10" x 14" Tom Tom
- 9838 16" x 18" Floor Tom Tom
- 6894 Titan Cymbal Stand
- 6904 Titan Cymbal Stand
- 6899 Titan Double Tom Tom Stand

**SUPERSTAR MEGA 50+3**

OUTFIT No. 9713

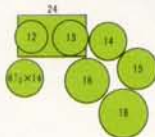

- 9812 8" x 12" Tom Tom
- 9815 12" x 15" Tom Tom
- 9836 16" x 16" Floor Tom Tom
- 6894 Titan Cymbal Stand
- 6904 Titan Cymbal Stand
- 6899 Titan Double Tom Tom Stand



50+4B

**SUPERSTAR 50+4B**

OUTFIT No. 9704B

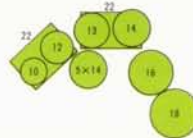

- 9822 14" x 22" Bass Drum
- 6692 Double Tom Tom Holder
- 9810 8" x 10" Tom Tom
- 9814 10" x 14" Tom Tom
- 9838 16" x 18" Floor Tom Tom
- 6755 King-Beat Drum Pedal
- 6894 Titan Cymbal Stand
- 6904 Titan Cymbal Stand

**SUPERSTAR MEGA 50+4B**

OUTFIT No. 9714B

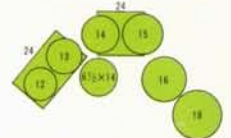

- 9824 14" x 24" Bass Drum
- 6692 Double Tom Tom Holder
- 9812 8" x 12" Tom Tom
- 9815 12" x 15" Tom Tom
- 9836 16" x 16" Floor Tom Tom
- 6755 King-Beat Drum Pedal
- 6894 Titan Cymbal Stand
- 6904 Titan Cymbal Stand



MEGA 50+5X



MEGA 50+4B



## SUPERSTAR 70

OUTFIT No. 9727

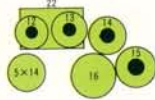

- 9822 14" x 22" Bass Drum
- 6692 Double Tom Tom Holder
- 8055 5" x 14" Snare Drum
- 9862 8" x 12" Concert Tom Tom
- 9863 9" x 13" Concert Tom Tom
- 9864 10" x 14" Concert Tom Tom
- 9865 12" x 15" Concert Tom Tom
- 9836 16" x 16" Floor Tom Tom
  
- 6755 King-Beat Drum Pedal
- 6890 Titan Snare Stand
- 6895 Titan Hi-hat Stand
- 6892 Titan Cymbal Stands (2)
- 6899 Titan Double Tom Tom Stand
- 5B Drum Sticks

Cymbals not included.

## SUPERSTAR MEGA 70

OUTFIT No. 9737

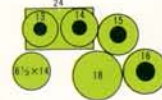

- 9824 14" x 24" Bass Drum
- 6692 Double Tom Tom Holder
- 8056 6 1/2" x 14" Snare Drum
- 9863 9" x 13" Concert Tom Tom
- 9864 10" x 14" Concert Tom Tom
- 9865 12" x 15" Concert Tom Tom
- 9866 14" x 16" Concert Tom Tom
- 9838 16" x 18" Floor Tom Tom
  
- 6755 King-Beat Drum Pedal
- 6890 Titan Snare Stand
- 6895 Titan Hi-hat Stand
- 6892 Titan Cymbal Stands (2)
- 6899 Titan Double Tom Tom Stand
- 5B Drum Sticks

Cymbals not included.

Finish Shown: Super Mahogany



SUPERSTAR MEGA 70+3





SUPERSTAR MEGA 70

**SUPERSTAR 70+3**

OUTFIT No. 9730

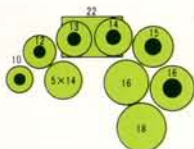

- 9860 6 1/2" x 10" Concert Tom Tom
- 9866 14" x 16" Concert Tom Tom
- 9838 16" x 18" Floor Tom Tom
- 6894 Titan Cymbal Stand
- 6904 Titan Cymbal Stand
- 6899 Titan Double Tom Tom Stand

**SUPERSTAR MEGA 70+3**

OUTFIT No. 9740

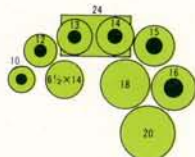

- 9860 6 1/2" x 10" Concert Tom Tom
- 9862 8" x 12" Concert Tom Tom
- 9840 18" x 20" Floor Tom Tom
- 6894 Titan Cymbal Stand
- 6904 Titan Cymbal Stand
- 6899 Titan Double Tom Tom Stand

**SUPERSTAR 70+6B**

OUTFIT No. 9733B

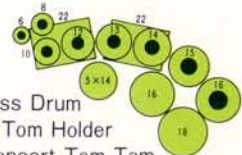

- 9822 14" x 22" Bass Drum
- 6692 Double Tom Tom Holder
- 9856 5 1/2" x 6" Concert Tom Tom
- 9858 5 1/2" x 8" Concert Tom Tom
- 9860 6 1/2" x 10" Concert Tom Tom
- 9866 14" x 16" Concert Tom Tom
- 9838 16" x 18" Floor Tom Tom
- 6755 King-Beat Drum Pedal
- 6894 Titan Cymbal Stand
- 6904 Titan Cymbal Stand
- 6909 Titan Double Tom Tom Stand
- 67-J Cymbal Holder

**SUPERSTAR MEGA 70+4B**

OUTFIT No. 9741B

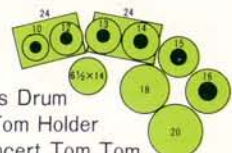

- 9824 14" x 24" Bass Drum
- 6692 Double Tom Tom Holder
- 9860 6 1/2" x 10" Concert Tom Tom
- 9862 8" x 12" Concert Tom Tom
- 9840 18" x 20" Floor Tom Tom
- 6755 King-Beat Drum Pedal
- 6894 Titan Cymbal Stand
- 6904 Titan Cymbal Stand



SUPERSTAR 70+6B



## SPECIAL SETS

While most players will find what they need on the previous pages, the following special sets have proven to be popular enough to be devoted space in this catalog. We hope they provide you with some inspiration.



### SUPERSTAR SP-7B

OUTFIT No. 9747S

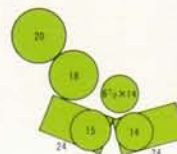

- 9824 14" x 24" Bass Drums (2)
- 8056 6 1/2" x 14" Snare Drum
- 9814 10" x 14" Tom Tom
- 9815 12" x 15" Tom Tom
- 9838 16" x 18" Floor Tom Tom
- 9840 18" x 20" Floor Tom Tom
- 6755 King-Beat Drum Pedals (2)
- 6890 Titan Snare Stand
- 6895 Titan Hi-hat Stand
- 6892 Titan Cymbal Stands (2)
- 6894 Titan Cymbal Stand
- 6904 Titan Cymbal Stand
- 6899 Titan Double Tom Stand
- 5B Drum Sticks

Cymbals not included.  
Finish Shown: Aqua Marine



### SUPERSTAR SP-9GB

OUTFIT No. 9749G

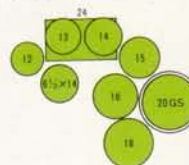

- 9824 14" x 24" Bass Drum
- 8056 6 1/2" x 14" Snare Drum
- 9812 8" x 12" Tom Tom
- 9813 9" x 13" Tom Tom
- 9814 10" x 14" Tom Tom
- 9815 12" x 15" Tom Tom
- 9836 16" x 16" Floor Tom Tom
- 9838 16" x 18" Floor Tom Tom
- 9850R14" x 20" Gong Bass w/Stand
- 6755 King-Beat Drum Pedal
- 6890 Titan Snare Stand
- 6895 Titan Hi-hat Stand
- 6892 Titan Cymbal Stands (2)
- 6894 Titan Cymbal Stand
- 6904 Titan Cymbal Stand
- 6899 Titan Double Tom Stands (2)
- 5B Drum Sticks

Cymbals not included.  
Finish Shown: Super Maple





LENNY WHITE



### SUPERSTAR SP-5/4H

OUTFIT No. 9745H

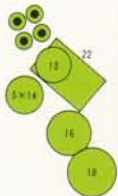

- 9822 14" x 22" Bass Drum
- 6681 Single Tom Tom Holder
- 8055 5" x 14" Snare Drum
- 9813 9" x 13" Tom Tom
- 9836 16" x 16" Floor Tom Tom
- 9838 16" x 18" Floor Tom Tom
- 7800-4H Octoban Hi-Pitch 4 pcs. set
- 6755 King-Beat Drum Pedal
- 6890 Titan Snare Stand
- 6895 Titan Hi-hat Stand
- 6892 Titan Cymbal Stands (2)
- 6894 Titan Cymbal Stand
- 67-J Cymbal Holder
- 5B Drum Sticks

Cymbals not included.  
Finish Shown: Super Mahogany



### SUPERSTAR SP-4J

OUTFIT No. 9744J

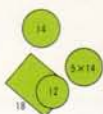

- 9818 14" x 18" Bass Drum
- 6681 Single Tom Tom Holder
- 8055 5" x 14" Snare Drum
- 9812 8" x 12" Tom Tom
- 9834 14" x 14" Floor Tom Tom
- 6755 King-Beat Drum Pedal
- 6890 Titan Snare Stand
- 6895 Titan Hi-hat Stand
- 6892 Titan Cymbal Stands (2)
- 5B Drum Sticks

Cymbals not included.  
Finish Shown: Super Maple



MICK FLEETWOOD  
(FLEETWOOD MAC)





STEWART COPELAND  
(THE POLICE)

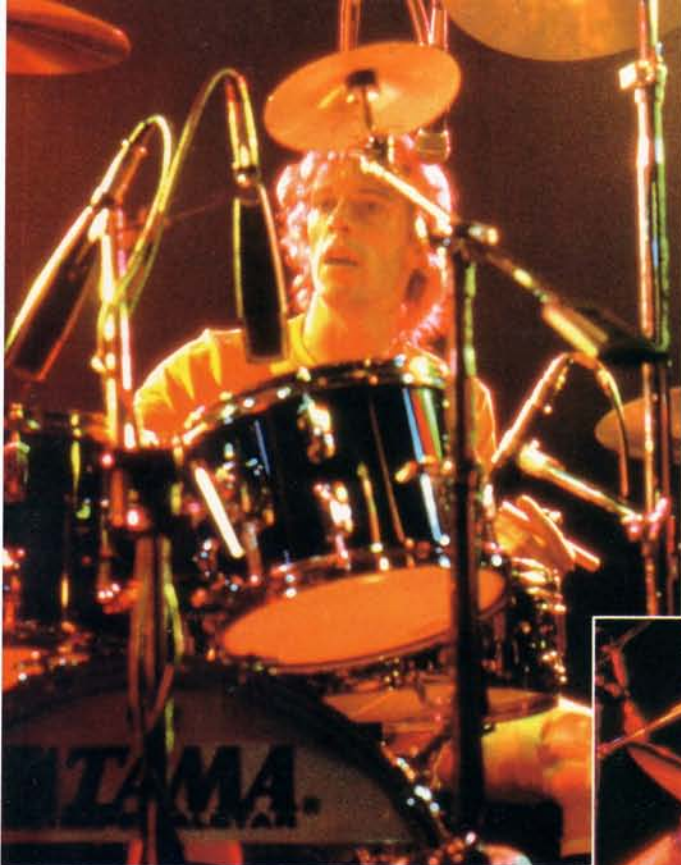

STAN LYNCH  
(TOM PETTY &  
HEARTBREAKERS)



SIMON PHILLIPS  
(STANLEY CLARK GROUP)



SIMON CROWE  
(BOOMTOWN  
RATS)

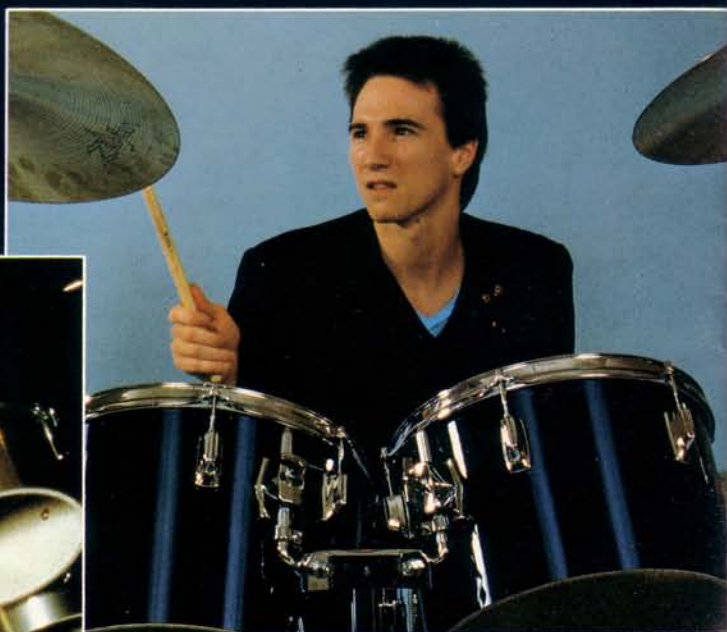

TERRY BOZZIO  
(U.K.)

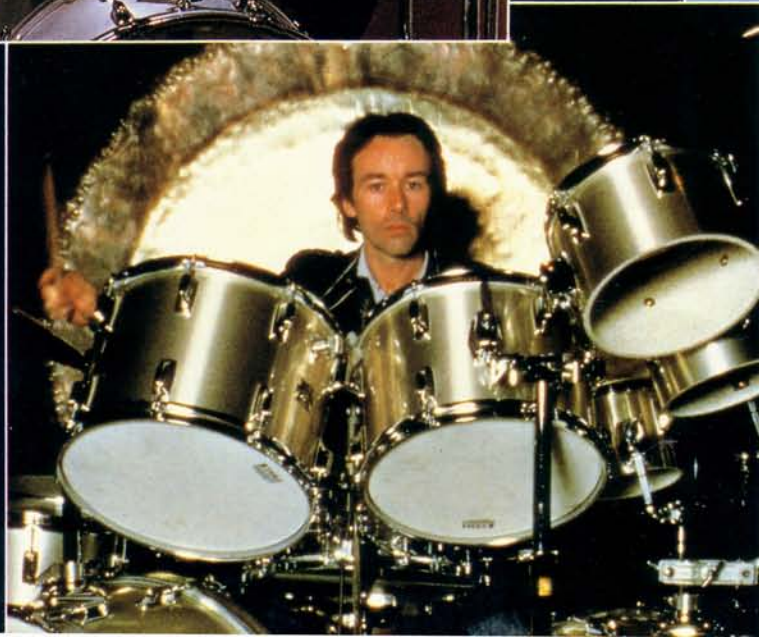

BRIAN DOWNEY  
(THIN LIZZY)



## TAMA IMPERIALSTAR DRUMS



**IMPERIALSTAR** - The heavyweight standard for wood drums.

The unique characteristic of Imperialstar drums is that they are made from 9 plies of select mahogany. Mahogany has a very consistent strength per unit of cross section, resulting in a drum of very uniform performance under all conditions. Imperialstar drums are loud, resonant and have great drum-to-drum balance.

The Heat Compression shell is additionally strengthened by two reinforcing rims inside the shell. The inside of the shell is finished with "Zola-Coat" a tough durable finish that provides an excellent moisture barrier for consistency of sound year in and out.

In the few short years that they have been available, Imperialstar drums have proven themselves on the road and in the studio with some of the world's hardest playing and hardest touring bands.

### ONE-TOUCH TONE CONTROL

Imperialstar tom toms feature the exclusive Tama One-Touch Tone Control. The exact amount of muffling can be preset and bought in and out at will.



## IMPERIALSTAR INDIVIDUAL DRUMS

In addition to being available in sets, Imperialstar drums are available individually to allow you to add to your existing set or to custom design your own set from the ground up. All Imperialstar drums (with the exception of concert toms) are furnished with Tama Ambassador heads as standard equipment.



### BASS DRUMS include spurs.

- 8522 14" x 22"
- 8524 14" x 24"
- 8526 14" x 26"

Imperialstar bass drums are furnished individually with both heads and spurs mounted. There is no tom holder supplied on individual bass drums and must be ordered separately.

### TOM TOMS

- 8508 8" x 8"
- 8510 8" x 10"
- 8512 8" x 12"
- 8513 9" x 13"
- 8514 10" x 14"
- 8515 12" x 15"

Imperialstar tom toms are furnished complete with Key-Lock mounting brackets. These brackets are compatible with any Tama tom tom holder or tom tom stand.

### FLOOR TOM TOMS include legs.

- 8534 14" x 14"
- 8536 16" x 16"
- 8538 16" x 18"
- 8540 18" x 20"

Tama floor tom tom legs use an offset design for maximum stability. The foot of the leg is a large rubber tip and the top of the leg is knurled for a rigid leg-to-bracket fit.



## CONCERT TOM TOMS

Imperialstar concert tom toms are furnished individually or in sets with Tama C.S. heads as standard equipment. The rugged dependability and excellent volume and tone of Imperialstar concert tom toms are fast making them a favorite among drummers. Imperialstar concert tom toms feature the same Key-Lock bracket as double headed tom toms for perfect interchangeability around your set.



Each individual Concert tom tom features a serial number imprinted on the medallion. If you've ever tried to insure your set, you'll know what a help this can be.

- |                  |                   |
|------------------|-------------------|
| 8556 5 1/2" x 6" | 8560 6 1/2" x 10" |
| 8558 5 1/2" x 8" | 8562 8" x 12"     |
| 6899 Stand       | 6899 Stand        |

### Hi-Pitch outfit No. 8568

- |                |                |
|----------------|----------------|
| 8563 9" x 13"  | 8565 12" x 15" |
| 8564 10" x 14" | 8566 14" x 16" |
| 6899 Stand     | 6899 Stand     |

### Low-Pitch outfit No. 8569

### Complete 8-pcs. outfit No. 8570





50

**MARS 50**

**OUTFIT No. 8400**

- 8522 14" x 22" Bass Drum
- 6692 Double Tom Tom Holder
- 8065 5" x 14" Snare Drum
- 8512 8" x 12" Tom Tom
- 8513 9" x 13" Tom Tom
- 8536 16" x 16" Floor Tom Tom
- 6740 Hi-Beat Drum Pedal
- 6890 Titan Snare Stand
- 6895 Titan Hi-hat Stand
- 6892 Titan Cymbal Stands (2)
- 5B Drum Sticks

Cymbals not included.  
Finish Shown: Metallic White



50+1

**MARS 50+1**

**OUTFIT No. 8401**

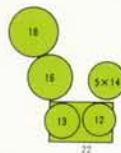

- 8538 16" x 18" Floor Tom Tom
- 6894 Titan Cymbal Stand



50+2

**MARS 50+2**

**OUTFIT No. 8402**

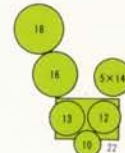

- 8510 8" x 10" Tom Tom
- 8538 16" x 18" Floor Tom Tom
- 6894 Titan Cymbal Stand
- 67-L Triple Tom Tom Adaptor

**MARS MEGA 50**

**OUTFIT No. 8410**

- 8524 14" x 24" Bass Drum
- 6692 Double Tom Tom Holder
- 8066 6 1/2" x 14" Snare Drum
- 8513 9" x 13" Tom Tom
- 8514 10" x 14" Tom Tom
- 8538 16" x 18" Floor Tom Tom
- 6740 Hi-Beat Drum Pedal
- 6890 Titan Snare Stand
- 6895 Titan Hi-hat Stand
- 6892 Titan Cymbal Stands (2)
- 5B Drum Sticks

Cymbals not included.  
Finish Shown: Jet Black

**MARS MEGA 50+1**

**OUTFIT No. 8411**

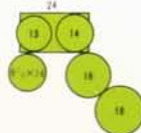

- 8536 16" x 16" Floor Tom Tom
- 6894 Titan Cymbal Stand

**MARS MEGA 50+2**

**OUTFIT No. 8412**

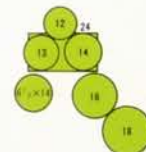

- 8512 8" x 12" Tom Tom
- 8536 16" x 16" Floor Tom Tom
- 6894 Titan Cymbal Stand
- 67-L Triple Tom Tom Adaptor



MEGA 50



MEGA 50+1



MEGA 50+3X





50+3



50+4B

### THE "50" SET

If there's such a thing as a standard drum set, it's the 5-piece. In the Tama line these standard 5-piece sets carry a "50" number designation.

This means that the set includes a 14" x 22" bass drum, 8" x 12" and 9" x 13" tom toms, 16" x 16" floor tom tom, 5" x 14" snare drum and the standard compliment of hardware including two straight cymbal stands, hi-hat stand, bass drum pedal and snare stand. Whenever a set carries a "50+1, 2, 3, etc." designation, it indicates that 1, 2, 3, etc. drums have been added to the basic 5-piece sets to create a 6, 7, 8, etc. piece drum set. When a set carries a "B" suffix, it indicates that a second bass drum has been added.

### THE "MEGA 50" SET

A Mega 50 set is a five-piece set featuring oversized drums.

### MARS MEGA 50+3X

OUTFIT No. 8413X

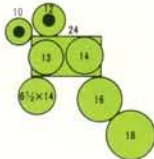

- 8560 6 1/2" x 10" Concert Tom Tom
- 8562 8" x 12" Concert Tom Tom
- 8536 16" x 16" Floor Tom Tom
- 6894 Titan Cymbal Stand
- 6904 Titan Cymbal Stand
- 6899 Titan Double Tom Tom Stand

### MARS 50+3

OUTFIT No. 8403

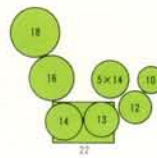

- 8510 8" x 10" Tom Tom
- 8514 10" x 14" Tom Tom
- 8538 16" x 18" Floor Tom Tom
- 6894 Titan Cymbal Stand
- 6904 Titan Cymbal Stand
- 6899 Titan Double Tom Tom Stand

### MARS MEGA 50+3

OUTFIT No. 8413

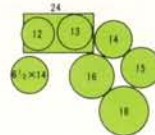

- 8512 8" x 12" Tom Tom
- 8515 12" x 15" Tom Tom
- 8536 16" x 16" Floor Tom Tom
- 6894 Titan Cymbal Stand
- 6904 Titan Cymbal Stand
- 6899 Titan Double Tom Tom Stand

### MARS 50+4B

OUTFIT No. 8404B

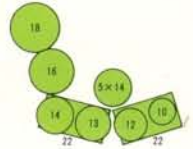

- 8522 14" x 22" Bass Drum
- 6692 Double Tom Tom Holder
- 8510 8" x 10" Tom Tom
- 8514 10" x 14" Tom Tom
- 8538 16" x 18" Floor Tom Tom
- 6740 Hi-Beat Drum Pedal
- 6894 Titan Cymbal Stand
- 6904 Titan Cymbal Stand

### MARS MEGA 50+4B

OUTFIT No. 8414B

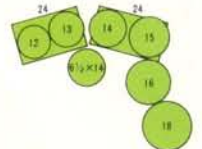

- 8524 14" x 24" Bass Drum
- 6692 Double Tom Tom Holder
- 8512 8" x 12" Tom Tom
- 8515 12" x 15" Tom Tom
- 8536 16" x 16" Floor Tom Tom
- 6740 Hi-Beat Drum Pedal
- 6894 Titan Cymbal Stand
- 6904 Titan Cymbal Stand



MEGA 50+3



MEGA 50+4B





70

**SATURN 70**

OUTFIT No. 8427

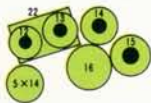

- 8522 14" x 22" Bass Drum
- 6692 Double Tom Tom Holder
- 8065 5" x 14" Snare Drum
- 8562 8" x 12" Concert Tom Tom
- 8563 9" x 13" Concert Tom Tom
- 8564 10" x 14" Concert Tom Tom
- 8565 12" x 15" Concert Tom Tom
- 8536 16" x 16" Floor Tom Tom

- 6740 Hi-Beat Drum Pedal
- 6890 Titan Snare Stand
- 6895 Titan Hi-hat Stand
- 6892 Titan Cymbal Stands (2)
- 6899 Titan Double Tom Tom stand
- 5B Drum Sticks

Cymbals not included.  
Finish Shown: Platina

**SATURN MEGA 70**

OUTFIT No. 8437

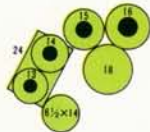

- 8524 14" x 24" Bass Drum
- 6692 Double Tom Tom Holder
- 8066 6 1/2" x 14" Snare Drum
- 8563 9" x 13" Concert Tom Tom
- 8564 10" x 14" Concert Tom Tom
- 8565 12" x 15" Concert Tom Tom
- 8566 14" x 16" Concert Tom Tom
- 8538 16" x 18" Floor Tom Tom

- 6740 Hi-Beat Drum Pedal
- 6890 Titan Snare Stand
- 6895 Titan Hi-hat Stand
- 6892 Titan Cymbal Stands (2)
- 6899 Titan Double Tom Tom Stand
- 5B Drum Sticks

Cymbals not included.  
Finish Shown: Royal Pewter



70+3

**SATURN 70+2**

OUTFIT No. 8429

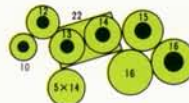

- 8560 6 1/2" x 10" Concert Tom Tom
- 8566 14" x 16" Concert Tom Tom
- 6894 Titan Gymbal Stand
- 6899 Titan Double Tom Tom Stand

**SATURN MEGA 70+2**

OUTFIT No. 8439

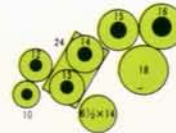

- 8560 6 1/2" x 10" Concert Tom Tom
- 8562 8" x 12" Concert Tom Tom
- 6894 Titan Cymbal Stand
- 6899 Titan Double Tom Tom Stand

**SATURN 70+3**

OUTFIT No. 8430

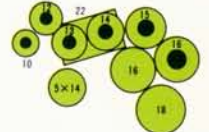

- 8560 6 1/2" x 10" Concert Tom Tom
- 8566 14" x 16" Concert Tom Tom
- 8538 16" x 18" Floor Tom Tom
- 6894 Titan Cymbal Stand
- 6904 Titan Cymbal Stand
- 6899 Titan Double Tom Tom Stand

**SATURN MEGA 70+3**

OUTFIT No. 8440

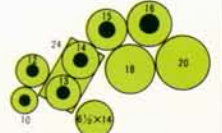

- 8560 6 1/2" x 10" Concert Tom Tom
- 8562 8" x 12" Concert Tom Tom
- 8540 18" x 20" Floor Tom Tom
- 6894 Titan Cymbal Stand
- 6904 Titan Cymbal Stand
- 6899 Titan Double Tom Tom Stand



MEGA 70



MEGA 70+2





70+5

**SATURN 70+5**

OUTFIT No. 8432

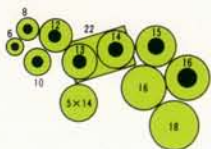

- 8556 5 1/2" x 6" Concert Tom Tom
- 8558 5 1/2" x 8" Concert Tom Tom
- 8560 6 1/2" x 10" Concert Tom Tom
- 8566 14" x 16" Concert Tom Tom
- 8538 16" x 18" Floor Tom Tom
- 6894 Titan Cymbal Stand
- 6904 Titan Cymbal Stand
- 6899 Titan Double Tom Tom Stand
- 6909 Titan Double Tom Tom Stand

**SATURN MEGA 70+5**

OUTFIT No. 8442

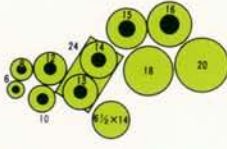

- 8556 5 1/2" x 6" Concert Tom Tom
- 8558 5 1/2" x 8" Concert Tom Tom
- 8560 6 1/2" x 10" Concert Tom Tom
- 8562 8" x 12" Concert Tom Tom
- 8540 18" x 20" Floor Tom Tom
- 6894 Titan Cymbal Stand
- 6904 Titan Cymbal Stand
- 6899 Titan Double Tom Tom Stand
- 6909 Titan Double Tom Tom Stand



MEGA 70+3



70+6B

**SATURN 70+6B**

OUTFIT No. 8433B

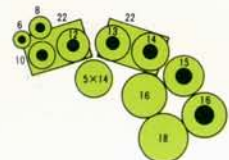

- 8522 14" x 22" Bass Drum
- 6692 Double Tom Tom Holder
- 8556 5 1/2" x 6" Concert Tom Tom
- 8558 5 1/2" x 8" Concert Tom Tom
- 8560 6 1/2" x 10" Concert Tom Tom
- 8566 14" x 16" Concert Tom Tom
- 8538 16" x 18" Floor Tom Tom
- 6740 Hi-Beat Drum Pedal
- 6894 Titan Cymbal Stand
- 6904 Titan Cymbal Stand
- 67-J Cymbal Holder
- 6909 Titan Double Tom Tom Stand



MEGA 70+4B

**SATURN 70+4B**

OUTFIT No. 8431B

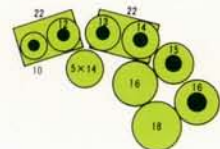

- 8522 14" x 22" Bass Drum
- 6692 Double Tom Tom Holder
- 8560 6 1/2" x 10" Concert Tom Tom
- 8566 14" x 16" Concert Tom Tom
- 8538 16" x 18" Floor Tom Tom
- 6740 Hi-Beat Drum Pedal
- 6894 Titan Cymbal Stand
- 6904 Titan Cymbal Stand

**SATURN MEGA 70+4B**

OUTFIT No. 8441B

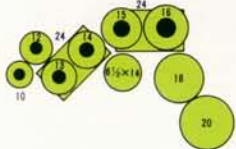

- 8524 14" x 24" Bass Drum
- 6692 Double Tom Tom Holder
- 8560 6 1/2" x 10" Concert Tom Tom
- 8562 8" x 12" Concert Tom Tom
- 8540 18" x 20" Floor Tom Tom
- 6740 Hi-Beat Drum Pedal
- 6894 Titan Cymbal Stand
- 6904 Titan Cymbal Stand

**SATURN MEGA 70+6B**

OUTFIT No. 8443B

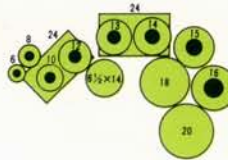

- 8524 14" x 24" Bass Drum
- 6692 Double Tom Tom Holder
- 8556 5 1/2" x 6" Concert Tom Tom
- 8558 5 1/2" x 8" Concert Tom Tom
- 8560 6 1/2" x 10" Concert Tom Tom
- 8562 8" x 12" Concert Tom Tom
- 8540 18" x 20" Floor Tom Tom
- 6740 Hi-Beat Drum Pedal
- 6894 Titan Cymbal Stand
- 6904 Titan Cymbal Stand
- 67-J Cymbal Holder
- 6909 Titan Double Tom Tom Stand



## TAMA GONG BASS DRUMS

The new Tama Gong Bass Drum was developed in cooperation with Billy Cobham to extend the melodic range of his Tama set. This unique drum has a very deep, but very clear and resonant tone. Single headed in construction, the Gong Bass uses a head 2 inches larger in diameter than the shell. This allows for maximum freedom of vibration. The Gong principal would not be possible without the development of a new stand, so the new Tama Rollaway Stand was born. This stand will locate the Gong Bass in any desired position, while taking up a minimum of floor space. The casters are lockable, making the Rollaway Stand stable and immovable. Available in Super Maple only.

**9850R** Gong Bass Drum  
w/rollaway stand

**9850S** Gong Bass Drum  
w/Single-Arm stands (2)

Tama Gong Bass Drums are sold complete with rollaway stand or single-arm stands (2).



## TAMA OCTOBANS



### TAMA OCTOBAN FEATURES

**Eight Tune Lengths** - With equal head tension, Octobans produce a perfect diatonic octave. They can also be tuned in a wide variety of scales and pitches for almost limitless melodic/percussive effects.

**Fibre Construction** - There are no seams to split or open up. The fibre shell are the strongest of their type and are full 4 mm thick in **Mat Black** finish.

**Lathe-Turned Sound Edge** - For a precision head fit and maximum volume and attack.



**7800** Octoban 8 pcs. set

**7800/4H** Octoban 4 pcs.  
Hi-pitch set

**7800/4L** Octoban 4 pcs.  
Low-pitch set



## TAMA OCTOBANS OPENING A NEW WORLD OF MELODIC PERCUSSION

Today's drummer has to know more than just hitting it on the 2 and the 4. The world of drums and percussion has broadened its musical view in the last decade. And this expanding horizon has brought with it many new percussion products, and most importantly a new drum company, Tama - the strongest new name in drums.

And now from Tama-one of the most innovative and exciting drum products of the 80's-Octobans. These melodic drums are designed with a distinctive tonal color and now give the drummer the opportunity to put melody to work. Already, drummers such as the incredible Billy Cobham, and Gary Mallaber of the Steve Miller band are using and praising Octobans. Billy is using his Octobans to add melodic continuity and punctuation to his solos and Gary uses Octobans to add a melodic/percussive texture to several of Steve Miller's finely crafted tunes. And the experimentation with Octobans is sure to go on for a long long time.



## SUPERSTAR TIMBALES

Superstar timbales offer you an effective crossover to apply the unique timbal sound to your drum kit. Constructed of 6-ply birch, their tone is deeper and more resonant but with a distinct latin flavor.

Superstar timbales feature an unique tymph-tom tension lug and floating head for a clear ringing tone. They also utilize Tama Key-Lock mounting brackets so they'll be compatible with all tom tom holders and tom tom stands.

- 9802 Superstar Timbales  
Includes:  
6 1/2" x 13" & 6 1/2" x 14"  
Superstar wood shell timbales  
6899 Titan stand  
Super mahogany finish only





### TAMA SHELL SUPPORTER

With many drummers playing single headed bass drums, the Tama shell support can perform several functions. It will prevent ovaling of the shell due to tom tom weight, prevent damage in transit, and keep a pillow or other muffler in place.

6635 Shell Supporter



### HI-HAT HOLDER

This Tama specialty allows double bass drum users to bring their hi-hat right in close to their bass drum pedal. This extra heavy duty clamp will hold your hi-hat at just about any angle, often necessary to clear tom toms.

6323 Hi-hat Holder

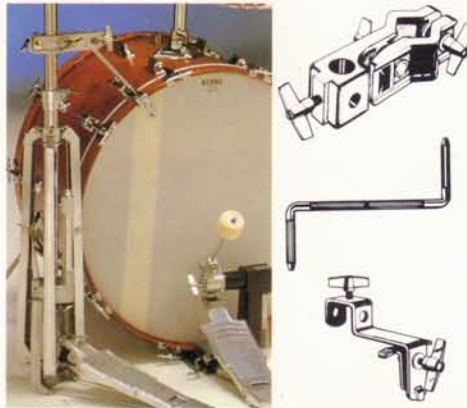

### CYMBAL HOLDERS

Tama offers two bass drum mount cymbal holders. The rim-clamp holder offers you the versatility of placement and the bracket-type holder does the job for permanent applications. Both feature a telescoping shaft and ratchet cymbal tilter.

6630 Shell Mount Cymbal Holder, set

6628 Hoop Mount Cymbal Holder, set



### TAMA 2-WAY BASS DRUM SPURS

Tama bass drum spurs feature the Tama 2-Way convertible tip. The rubber tip easily retracts to expose a sharp and gripping anchor tip. Tama bass drum spurs are slanted forward 15° to virtually eliminate bass drum creep.

6580 Bass Drum Spurs, set



### FLOOR TOM TOM LEGS

Tama floor tom tom legs use an offset design for maximum stability. The foot of the leg is a large rubber tip and the top of the leg is knurled for a rigid leg-to-bracket fit.

6583 Floor Tom Tom Legs, set of 3



### QUICK-RELEASE EXTERNAL TONE CONTROL

This new external muffler is ideal for toms and snare drum alike. The precise amount of control can be adjusted and the quick release lever lets you turn the muffler on and off without disturbing the tone setting.

6553 Quick-Release External Tone Control



### BASS DRUM ANCHOR

A bass drum rim clamp anchor with either rubber tips or stage spikes. Provides additional protection against bass drum creep.

6348 Bass Drum Anchor



### TAMA DRUM KEY

Die-cast key fits all standard square head tension rods.

6560 Drum Key





## TAMA - THE OAK STICKS

Unlike many drumsticks, Tama sticks are made from cured and seasoned oak. But why oak? Oak is a very hard wood with excellent grain consistency from piece to piece. When properly cured, oak is very stable and will resist warping to a great degree. When

applied to drumsticks, these properties are most important. First of all, a hard stick will be durable. Oak sticks resist chipping and cracking better than any others. Also, a hard stick will be very lively, with excellent rebound from both drums and cymbals.

What does grain consistency mean? It means that every stick of a particular

size and demension will weight almost exactly the same as any other of the same size stick, and will balance and respond exactly the same. Sticks of other materials often vary in weight and balance, so finding a matched pair can be a real hassle.



<b>5A</b> 16" MED. THIN	<b>7A</b> 15 <sup>3</sup> / <sub>8</sub> " MED. THIN	<b>3A</b> 15 <sup>7</sup> / <sub>8</sub> " MED.	<b>ROCK</b> <b>105</b> 16 <sup>2</sup> / <sub>8</sub> " MED.	<b>ROCK</b> <b>202</b> 16" MED.	<b>11A</b> 16" MED. HEAVY	<b>5B</b> 16" MED. HEAVY	<b>305B</b> 16" MED. HEAVY	<b>2B</b> 16" MED. HEAVY	<b>3S</b> 17" EXTRA HEAVY
----------------------------------	---	---	---	--	------------------------------------	-----------------------------------	-------------------------------------	-----------------------------------	------------------------------------

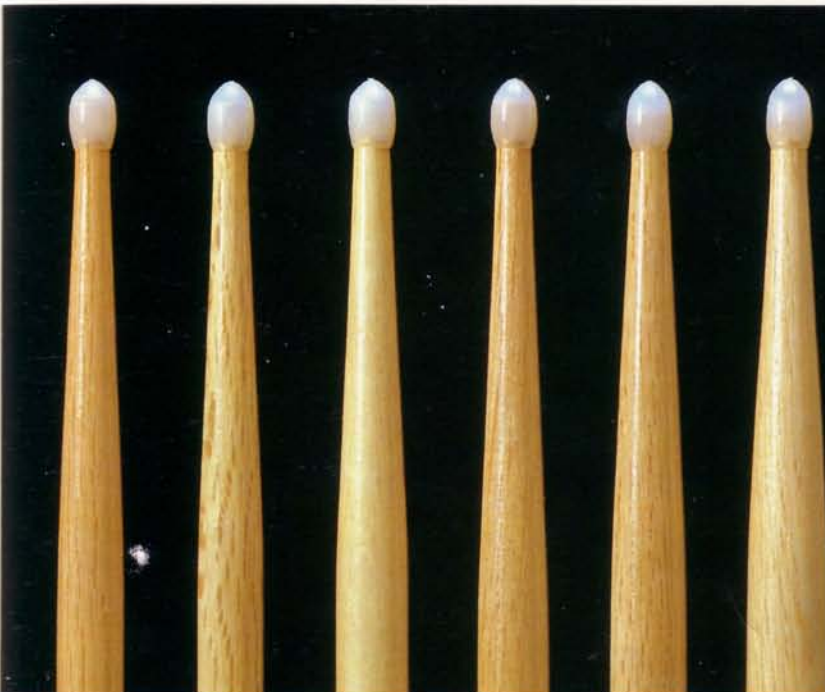

<b>5AN</b> 16" MED. THIN	<b>7AN</b> 15 <sup>3</sup> / <sub>8</sub> " MED. THIN	<b>ROCK</b> <b>105N</b> 16 <sup>2</sup> / <sub>8</sub> " MED.	<b>ROCK</b> <b>202N</b> 16" MED.	<b>5BN</b> 16" MED. HEAVY	<b>2BN</b> 16" MED. HEAVY
-----------------------------------	--	--	---	------------------------------------	------------------------------------

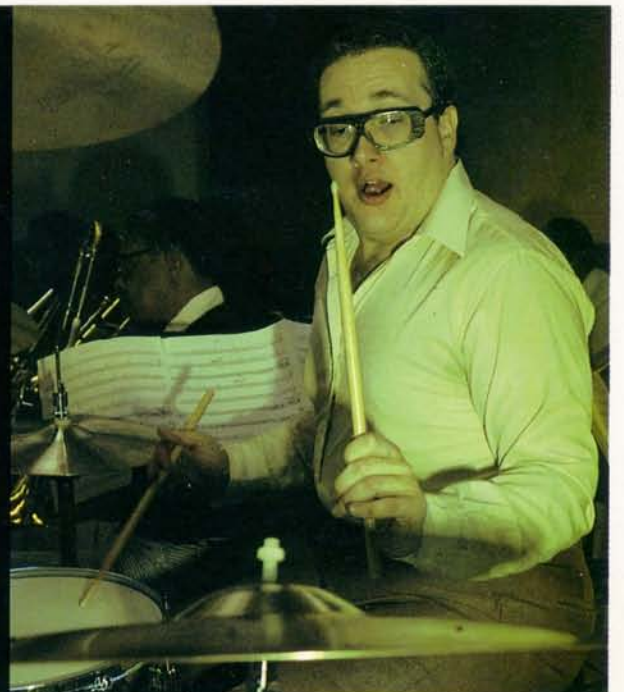

DRUMS: DUFFY JACKSON  
COUNT BASIE ORCHESTRA  
PHOTO: STEVE WEISS



## PARTS KIT - PARTS CATALOG

Tama offers two parts kits – one for drums and one for hardware. Both include all you'll need, on the road or in the shop. Custom cabinet is included. The Tama parts catalog is also available to help you find exactly the part you need. It features detailed exploded views of all Tama parts and hardware.



## STAND PARTS KIT

### No. SK-6702

- 4 pcs. 1 Plastic bushings w/pin  
usage: stands (big 28.6)
- 2 pcs. 2 Plastic bushings w/pin  
usage: stands (medium 22.2)
- 2 pcs. 3 Plastic bushing w/pin  
usage: stands (small 19.1)
- 1 pc. 4 Wing screw 6m/m-small knob  
usage: stands
- 3 pcs. 5 Thumb screws  
usage: stands
- 2 pcs. 6 Rubber tip assemblies  
usage: spartan stands (6920-6925)
- 2 pcs. 7 Rubber tips  
usage: titan stands (6890-6895)
- 2 pcs. 8 Rubber tips  
usage: mercury stands (6870-6875)
- 2 pcs. 9 Felt washers  
usage: hi-hat bottom seat
- 2 pcs. 10 Metal washers  
usage: hi-hat bottom seat
- 2 pcs. 11 Bolt & nut assemblies  
usage: hi-hat bottom seat
- 1 pc. 12 Hi-hat strap assemble  
usage: hi-hat stands
- 3 pcs. 13 Non-loose hex nuts  
usage: hi-hat stands
- 1 pc. 14 Hi-hat clutch complete  
usage: hi-hat stands
- 2 pcs. 15 Non-loose plastic nuts  
usage: hi-hat stands
- 1 pc. 16 Snare bolt & nut assembly  
usage: snare stands
- 2 pcs. 17 Wing nuts  
usage: stands & brackets
- 3 pcs. 18 Nylon treaded tube  
usage: cymbal stands
- 3 pcs. 19 Felt washers  
usage: cymbal stands
- 2 pcs. 20 Bolt & nut assembly  
usage: cymbal stands

## DRUM PARTS KIT

### No. DK-6704

- 2 pcs. 1 "T" rods  
usage: bass drums
- 10 pcs. 2 washers  
usage: all rods
- 2 pcs. 3 Hooks  
usage: bass drum rods
- 5 pcs. 4 Rods  
usage: floor tom toms
- 10 pcs. 5 Rods  
usage: snare & tom toms
- 2 pcs. 6 Lugs  
usage: tom toms
- 1 pc. 7 Lugs  
usage: snare drums
- 1 pc. 8 Lugs  
usage: bass drums
- 10 pcs. 9 Lug nuts  
usage: all lugs
- 10 pcs. 10 Nylon lug nut stoppers  
usage: all lugs
- 10 pcs. 11 Mounting screws  
usage: all lugs
- 1 pc. 12 Rubber tips  
usage: spurs & legs
- 3 pcs. 13 Thumb screws  
usage: tom holders & spurs
- 5 pcs. 14 Plastic straps  
usage: snappy snares
- 1 pc. 15 Eye bolt assembly  
usage: mounting brackets
- 2 pcs. 16 Wing nuts  
usage: tom tom holder & brackets
- 2 pcs. 17 Bolt & nut assemblies  
usage: tom tom holders
- 2 pcs. 18 Rubber tips  
usage: floor tom tom legs
- 5 pcs. 19 Screws  
usage: snare butt plates
- 2 pcs. 20 Tone control dampers  
usage: all drums

## TAMA DRUM WARRANTY

Tama drums are guaranteed against defects in materials and workmanship for a period of five years from the date of original retail purchase. Tama drum shells are warranted against going out of round or splitting. Tama hoops are warranted against breakage under normal use. This warranty is subject to the limitations contained here in, and is extended to the original retail purchaser only, and is not transferable.

This warranty does not cover any instruments that have been altered or modified or which have been damaged through misuse, negligence, accident or improper operation. Normal wear and tear, sound, heads, plating, drumsticks, brushes, beaters, spring, traps and damages in

shipping and transport are not covered. This warranty is not extended to instruments purchased from an unauthorized dealer. Tama makes no other express warranty of any kind whatsoever. All implied warranties, including warranties of merchantability and fitness for a particular purpose, exceeding the duration of this warranty are hereby disclaimed and excluded from this warranty. Tama disclaims liability for any incidental and consequential damages arising out of the use of this product. All warranty claims will be handled by an Authorized Tama Service Center. The defective instrument must be returned to the Tama Service Center freight and insurance prepaid only after proper return authorization has been

approved. We suggest that this return be handled by an authorized Tama dealer. Upon inspection and evaluation, Tama alone will determine the extent of liability and will notify the claimant as to the decision. Repaired instruments will be returned to the claimant freight collect.



SUPERSTAR



IMPERIALSTAR

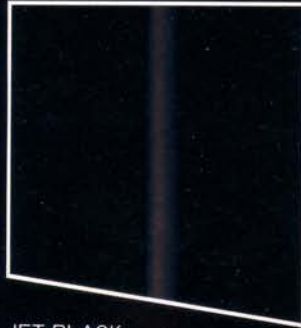

SUPER MAHOGANY

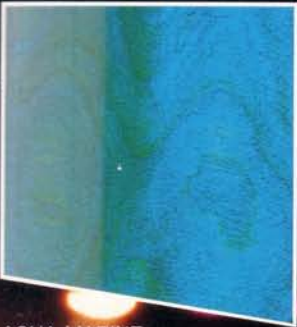

JET BLACK



AQUA MARINE



PLATINA

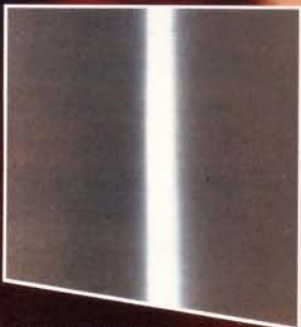

SUPER MAPLE



ROYAL PEWTER



METALLIC WHITE

NOTE: Additional colors may be available, but will vary from country to country. Consult your Tama dealer for availability in your area.



# TAMA

TAMA DRUMS ARE SOLD AND SERVICED BY